

GEORGETOWN UNIVERSITY
GRADUATE SCHOOL



The dissertation of Mazen Al-Waerentitled

TOWARD A MODERN AND REALISTIC SENTENTIAL THEORY
OF BASIC STRUCTURES IN STANDARD ARABIC

submitted to the department of Linguisticsin partial

fulfillment of the requirements for the degree of Doctor of Philosophy
in the Graduate School of Georgetown University has been read and approved by the
Committee:

Walter C. Cook Jr

Alexa T. M'Cray

J.P. Penner Jr

W.K. Kreidler

Head of Department

March 29, 1983

Date

جامعة جورج تاون
انكلترا

نحو نظرية جمالية واقعية وحديثة
للتراكيب الاساسية
في اللغة العربية الفصحى

رسالة دكتوراة
باللغة الانجليزية

تقديم
مازن الوعر

١٠٠٣٠٨٦

جامعة جورج تاون - انكلترا

١٤٠٣ هـ - ١٩٨٣ م



TOWARD A MODERN AND REALISTIC SENTENTIAL THEORY
OF BASIC STRUCTURES IN STANDARD ARABIC

A Dissertation
submitted to the Faculty of the
Graduate School of Georgetown University
in partial fulfillment of the requirements for the
degree of
Doctor of Philosophy in Linguistics

By

Mazen Al-Waer

Washington, D. C.

March 1983

ABSTRACT

This study has two goals: to contribute some Arabic linguistic insights to the expanding knowledge of sentential theory, and to apply some modern linguistic technicalities and methods to the analysis of basic sentential structures in Arabic. Thus, within the scope of these two goals, this study is an attempt to provide an accurate analysis of the basic structures in Arabic and at the same time to expand the general sentential theory in Universal Grammar. The work draws its theoretical framework from three sources: the basic transformational generative grammar proposed by Chomsky, the case grammar matrix model proposed by Cook, and the Arabic grammar proposed by the early Arab grammarians in the eighth century A.D. The new framework is applied to the following structures:

- (1) Verbal structures
- (2) Nominal structures
- (3) Question structures.

It is assumed that the base generates all these structures equally. The transformational rules then operate on these structures differently. The study investigates those base-generated and transformational rules and describes their freer and more restricted operations. It also attempts to propose some constraints on such rules.

These rules and their constraints cannot be formulated unless we understand the Arabic structures in the light of recent developments in linguistic theory.

Finally, the study provides some theoretical implications for both Arabic and Universal Grammar. The study shows that Arabic can be studied within the framework of Universal Grammar, provided that one takes account of those language features that are specific to the Arabic language.

Wa l-lāhu waliyyu t-tawfīq

ACKNOWLEDGMENTS

First and foremost, I would like to express my gratitude to my advisor, Professor Walter A. Cook, and the members of my committee, Professor Francis P. Dinneen and Professor Alexa McCray, for their challenging comments, their corrections, and their expeditious help.

I wish to avail myself of this opportunity to thank Professor Noam Chomsky, of the Massachusetts Institute of Technology (MIT), whose world-renowned scholarly work motivated me from a distance of ten thousand miles to study linguistics. I am grateful to him also for reading and commenting on this dissertation. I am also indebted to him and the faculty of the Linguistics Department at MIT for accepting me as a visiting scholar in the academic year of 1981-1982, and for allowing me the use of their valuable research facilities.

I would also like to express my sincere thanks to Professor Hussam Al-Khateeb, of Damascus University, for making it possible for me to come to the United States. I am indebted to him for his help, encouragement, and inspiration.

Thanks are also due to Professor Abdurrahman Haj Saleh, of the Algerian Institute of Linguistics, who was the first to open my eyes to linguistics while I was involved in literature.

Finally, thanks to my friends whose discussions were useful, valuable, and encouraging. Of the many, I would particularly like to thank Dr. Wallace Erwin, of Georgetown University; Dr. Kenneth Hale, of MIT; Dr. Rafic Jouejate, the Ambassador of the Syrian Arab Republic to the United States; and Ph.D. candidate Richard Sproat, of MIT.

الى روح أبي الطاهرة التي مانعت بروءية
صورتها إلا لثلاث سنين من العمر، فطيب
الله شراها رحمة ودعاء.
الى أمي المكافحة التي ما فتئت تشتغل
لتنهير درب الطريق من المهد، فأبقاها
الله ذخرا وعرفانا ووفاء.
أهدى هذه الشجرة المتواضعة من غرسهما

مازن الوعر

"...It is obviously a serious, impressive, and important piece of work, covering a very broad range and with very interesting ideas. I was particularly intrigued by the comments interspersed throughout on the Arab grammarians. That alone makes it a very valuable contribution, apart from the linguistic work, which looks most interesting."

Noam Chomsky (personal communication)

TABLE OF CONTENTS

	<u>Page</u>
ABSTRACT	
ACKNOWLEDGMENTS	iv
DEDICATION	vi
NOTE FROM NOAM CHOMSKY	vii
QUOTE FROM AL-JURJĀNI	xi
INTRODUCTION	1
1. Overview	1
2. Definition of Arabic	3
3. Transcription	4
CHAPTER ONE: ARABIC SENTENTIAL THEORY	7
0. Introduction	7
1. The Analysis of the Sentential Structures	7
1.1. The Nature of the Constituents of Kalām	9
1.1.1. Nominal Structure	9
1.1.2. Verbal Structure	11
1.1.3. Adverbial Structure	12
1.1.4. Conditional Structure	14
1.2. The Nature of Kalām as Large and Small	15
1.2.1. The Kubrā Sentence	16
1.2.2. The Ṣuġrā Sentence	17
1.3. The Nature of the Functional Roles of Kalām	18
1.3.1. The Functional Role of Sentence	18
1.3.2. The Declensional Role of Word	20

TABLE OF CONTENTS (Cont'd)

	<u>Page</u>
2. The Syntactic and Semantic Notions in the Sentential Structures.	23
2.1. Syntactic Notion.	23
2.2. Semantic Notion	28
CHAPTER TWO: TRANSFORMATIONAL GENERATIVE GRAMMAR THEORY	36
0. Introduction.	36
1. The Syntactic Theory of 1957.	37
2. The Standard Theory of 1965	39
3. The Extended Standard Theory.	43
3.1. The Lexicalist Theory	43
3.2. The Interpretive Theory.	45
3.3. Recent Syntactic and Semantic Modifications	48
4. Jackendoff's Syntactic-Thematic Model	49
4.1. The Thematic Theory of Gruber	49
4.2. The Syntactic-Thematic Theory of Jackendoff	52
4.3. The Advantages of Jackendoff's Model.	56
5. The Case Grammar Theory of Cook	57
5.1. The Matrix Model.	57
5.2. The Bidirectional System.	64
5.3. The Comparison between Case Theory and Thematic Theory.	67
CHAPTER THREE: BASIC STRUCTURES	70
0. Introduction.	70
1. Theoretical Framework	70
2. Word Order in Basic Structures.	81
2.1. Word Order in Verbal Structures	81
2.1.1. Constraints on Word Order in Verbal Structures.	86
2.1.2. Constraints on Unified Category and ?al-?i?ti?al Principles in Verbal Structures.	99

TABLE OF CONTENTS (Cont'd)

	<u>Page</u>
2.2. Word Order in Nominal Structures	108
2.2.1. Nominal Structures	108
2.2.2. Nominal Existential or Equational Structures	113
CHAPTER FOUR: QUESTION STRUCTURES	124
0. Introduction	124
1. The Theoretical Framework of the Yes-No-Question.	124
1.1. The Syntactic Aspects of the Yes-No-Question.	128
1.2. The Semantic Aspects of the Yes-No-Question.	139
2. The Theoretical Framework of the Information Question	142
2.1. Q-Movement in the Verbal Structures.	145
2.2. Q-Movement in the Nominal Verbal Structures.	147
2.3. Q-Movement in the Nominal Equational Structures.	153
2.4. The Syntactic and Semantic Constraints of the Information Question	157
2.4.1. Constraints on Independent Q-Phrases.	157
2.4.2. Constraints on the Unified Q-Phrases.	169
CHAPTER FIVE: THEORETICAL IMPLICATIONS	174
0. Introduction	174
1. Arabic Sentential Theory	174
2. Transformational Generative Grammar Theory	179
3. Basic Structures	181
4. Question Structures.	187
5. Conclusion	196
BIBLIOGRAPHY.	198
BIOGRAPHICAL NOTE	204

"It was reported that Ibn ?Al-Anbāri said:
 'The philosopher and translator ?Al-Kindi (Ya^cqūb
 Ibn Ishāq) went to see ?Al-Mubarrad (Abu l-^cabbās)
 [a well-known medieval Arab grammarian] and said to
 him: "I find too much redundancy in the speech of
 the Arabs." To this, ?Al-Mubarrad replied: "Where
 exactly do you find this?" ?Al-Kindi replied: "I
 see that the Arabs say

(a) $\frac{^c\text{abdullāhi}}{^c\text{Abdullāhi}}$ $\frac{\text{qā?imun}}{\text{standing up}}$
^cAbdullāhi is standing up.

(b) $\frac{?inna}{[\text{Comp}]}$ $\frac{^c\text{abdallāhi}}{^c\text{Abdallāhi}}$ $\frac{\text{qā?imun}}{\text{standing up}}$

(c) $\frac{?inna}{[\text{Comp}]}$ $\frac{^c\text{abdallāhi}}{^c\text{Abdallāhi}}$ $\frac{\text{la - qā?imun}}{\text{Adjunct standing up}}$

Thus different forms express the same meaning."
 ?Al-Mubarrad replied, "No, these are different
 meanings expressed by different forms: (a) informs
 us that ^cAbdullāhi is standing up; (b) is a reply
 to a question whether ^cAbdullāhi is standing up or
 not; and (c) is a response to a statement denying
 that ^cAbdullāhi is standing up. So the multiplicity
 of forms is due to the multiplicity of meaning."

"It was reported that the philosopher ?Al-Kindi
 was then at a loss as to what to say. If this matter
 was beyond ?Al-Kindi's grasp to the extent that he
 had to travel to inquire and question, then what
 would you expect of the layman for whom matters
 such as this one do not even cross his mind?"

Al-Jurjāni (d. 1078). Dalā'il ?al-?i^cjāz.
 Ed. 1961. Cairo, p. 206.

INTRODUCTION

1. Overview

In this study, I shall investigate the basic sentential structures in standard Arabic within the scope of a modern linguistic framework. Basic sentential structures include the following:

- (1) Verbal structures
- (2) Nominal structures
- (3) Question structures.

The study is intended to investigate the above structures within three frameworks: (a) the basic transformational grammar proposed by Chomsky, (b) the case grammar proposed by Cook (1979), and (c) the Arabic grammar proposed by the early Arab grammarians in the eighth century A.D. The study, however, will concentrate upon the Arabic structures being described and explained.

In Chapter One, the study will explain the Arabic sentential theory proposed by the early Arab grammarians. The explanation will cover two areas. The first is related to the sentential structures and their constituents. The second is related to the syntactic and semantic notions of these sentential structures.

In Chapter Two, the study will show the semantic modifications which have been developed in generative grammar.

These semantic modifications are shown with regard to the developments which were made by Chomsky from 1965 onward, including the thematic relations as developed in Gruber (1965) and Jackendoff (1972-1976). The study will also show independently the semantic development in the case grammar matrix model proposed by Cook (1979). I shall show, by using the matrix model as a descriptive semantic system, that we can reach a satisfactory semantic framework to describe and explain the Arabic structures.

In Chapter Three, I will develop a more adequate framework based on basic transformational grammar, case grammar, and Arabic grammar to describe and explain the Arabic structures syntactically and semantically. The structures which will be studied here are (a) verbal structures, and (b) nominal structures. The study will investigate the base-generated and transformational rules which operate on these structures. In doing so, the study will be able to capture both the freer and the more restricted movement produced by those generative rules. Consequently, the study will formalize some syntactic and semantic constraints on those generative rules in order to describe and explain accurately the basic structures in Arabic.

In Chapter Four, I will explain the structure of question formation. The explanation will cover two types of question formation. The first type is the yes-no question. The second type is the information question. The two types of question formation will operate on verbal structures and nominal

structures. The study will show the syntactic and semantic characters of both yes-no questions and information questions. The study will investigate the base-generated question and the transformational question. The study will also propose some syntactic and semantic constraints which are able to restrict the movement of the Q-category in order to generate grammatical structures.

In Chapter Five, I will show some theoretical implications for both linguistic theory and the Arabic language. The study will show that Arabic structures can be subsumed under the hypothesis of Universal Grammar, provided that one takes account of those language features which are specific to the Arabic language.

2. Definition of Arabic

The form of Arabic treated in this dissertation is standard Arabic, which is neither stylistically high nor stylistically low, but is rather a unifying literary form of all Arab nations. This standard Arabic form is used in schools, universities, textbooks, lectures, writing media, radio, television, in personal letters, and, on occasion, in speech among educated Arabs. In fact, linguistic literature has different terms to name the same variety used in this study, such as:

- (1) Literary Arabic
- (2) Standard Arabic
- (3) Modern standard Arabic
- (4) Modern written Arabic
- (5) Qurʾānic Arabic
- (6) Classical Arabic.

My belief is that Arabic has a uniform set of syntactic and phonological components. The main different component resides in the lexicon. This vocabulary difference is due to the historical development of Arabic which made contact with different languages and borrowed from them many lexical items. The major power of the solidarity of one Arabic form is due to its stylistic variations. Arabic ranges from the highly esteemed style of the Qurʾān to a very low stylistic level which is that of the spoken form of the home and the street. Thus, it is not surprising to see a person who does not know how to read and write understand perfectly the highly esteemed stylistic level of the Qurʾān or the somewhat lower level of the Arabic of the radio or television. At the same time, it is not surprising to find that an Arab thirteen-year-old understands pre-Islamic poetry.

3. Transcription

The phonetic symbols used in this study are basically those in IPA (1975).

(1) Consonants

1. [b] voiced bilabial stop
2. [t] voiceless apico-dental stop
3. [t̥] voiceless apico-dental emphatic stop
4. [d] voiced apico-dental stop
5. [d̥] voiced apico-dental emphatic fricative
6. [k] voiceless velar stop
7. [q] voiceless dorso-uvular stop
8. [ʔ] voiceless glottal stop
9. [j] voiced lamino-alveolar palatal affricate
10. [c] voiced radico-pharyngeal fricative
11. [f] voiceless labio-dental fricative
12. [θ] voiceless inter-dental fricative
13. [x^o] voiced inter-dental fricative
14. [x^o] voiced inter-dental emphatic fricative
15. [s] voiceless apico-alveolar fricative
16. [s̥] voiceless apico-alveolar emphatic fricative
17. [z] voiced apico-alveolar fricative
18. [ʃ] voiceless lamino-palatal fricative
19. [x] voiceless dorso-uvular fricative
20. [ɣ] voiced dorso-uvular fricative
21. [h̥] voiceless radico-pharyngeal fricative
22. [h] voiceless laryngeal fricative
23. [r] voiced apical trill roll
24. [l] voiced apico-alveolar lateral
25. [m] voiced bilabial nasal
26. [n] voiced apico-alveolar nasal
27. [w] voiced bilabial (rounded) velar glide
28. [y] voiced palatal (unrounded) glide

(2) Vowels

1. [i] voiced short high front unrounded vowel
2. [ī] voiced long high front unrounded vowel
3. [a] voiced short central unrounded vowel
4. [ā] voiced long central unrounded vowel
5. [u] voiced short high back rounded vowel
6. [ū] voiced long high back rounded vowel

CHAPTER ONE
ARABIC SENTENTIAL THEORY

0. Introduction

In this chapter, I shall explain the Arabic sentential theory proposed by the early Arab grammarians. The purpose of such an explanation is to probe the syntactic and semantic aspects of the Arabic sentential theory, in order to understand the Arabic structures in depth. I hope that, through such an analysis, I will be able to show that the ?aṣl, or the deep representation of the Arabic language as understood by the early Arab grammarians, provides a very useful insight for the sentential theory, which I will develop in Chapter Three.

1. The Analysis of the Sentential Structures

Arab grammarians distinguished two types of sentential structures: the first is called ?al-kalām (henceforth K). They meant by K 'independent sentence,' the meaningful form of language which any kind of sentence must be.¹ The second is called ?al-jumlah (henceforth J). They meant by J the pronouncable form of language which may or may not be a

¹Ibn Hiṣām (d. 1368) stated that "?al-kalām: huwa l-qawlu l-mufīd, i.e., ?al-kalām is a meaningful form." Ibn Hiṣām (d. 1368), Muḡni L-Labīb, Eds. Al-Mubārak, M., and Hamadallah, M., Damascus, 1969, p. 419.

sentence.² For example, the subordinate structure or conditional structure has no meaning unless it is joined to its main structure, even though it consists of a predicate and its subject. Thus the statement, "If sentence₁," is meaningless by itself.

The distinction between K and J, however, was not defined clearly and coherently, because some Arab grammarians considered them to be identical. The majority of Arab grammarians, however, considered K and J to be different. Thus, every K must be a J, because it consists of a complete syntactic and semantic form regardless of whether that structure is simple or complex. On the other hand, not every J would be K, because J might or might not have complete syntactic and semantic form (i.e., sentence). This can be seen from the following examples:

(1)* man yadrus → jumla
 who study
 He who studies

(2) man yadrus yanjah → kalām
 who study succeed
 He who studies will succeed.

²Ibn Hišām stated that, "?al-jumlah: ^cibāra ^can il-fi^cli wa fā^cilihi, i.e., ?al-jumlah is a predicate and its subject," Ibid., p. 419.

Arab grammarians such as Ibn Hišām analyzed the structure of K from a different perspective. They analyzed it according to (1) the nature of its initial constituents, (2) its nature as large or small, and (3) the nature of the functional role it plays.

1.1. The Nature of the Constituents of Kalām

According to the classification of Arab grammarians, there are four types of sentential structures. The Arab grammarians called them: Nominal Structure, Verbal Structure, Conditional Structure, and Adverbial Structure.

1.1.1. Nominal Structure

The nominal structure is any structure that starts with what the grammarians called Musnad ?ilayhi (MI), i.e., "initial constituent or topic," which might be sentence or noun phrase. The MI is followed by a sentence which might be a verbal structure, nominal equational structure, or NP-predicate. The sentential comment, regardless of its structural type, was called by Arab grammarians Musnad (M), i.e., M-predicate.

In fact, Arab grammarians did not call the sentential structure nominal because it starts with a noun, but because it starts with MI, i.e., Topic. Their argument was that the initial constituent or MI can be also of different categories. Thus, the MI might be a sentence as in (3a) and (3b):

- (3) a. tasma^ca bi - l-mu^{c̄}idiyyi xayrun min ?an tarā-h
 (you) hear about Mu^{c̄}id better than that you see him
 To hear about Mu^{c̄}id is better than to see him.

The Arab grammarians understood the structure of sentence (3a) as in (3b) configuration.

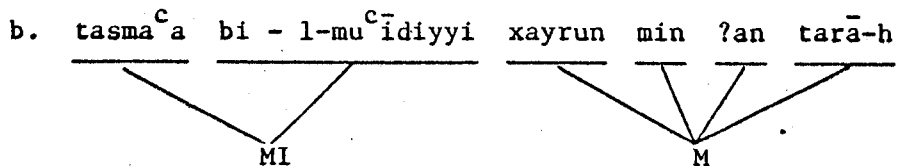

According to their sentential analysis, any structure having the order of MI-M is nominal. This is different, however, from the structure which has the order of M-MI, which is considered verbal. Thus, the most important fact about the nominal structure is that its initial constituents must be one of MI.

The three types of the nominal structure can be shown in (4), (5), and (6).

- (4)

MI	M
zaydun	ṣā ^{v-c} irun
Zayd	poet

 Zayd is a poet.

- (5)

MI	M
zaydun	?abū - hu ṣā ^{v-c} irun
Zayd	father his poet

 As for Zayd, his father is a poet.

(6)	MI		M						
	zaydun	ʔaḥabba	mayyan	ḥubban	jammā				
	Zayd	loved	Mayy	a love	great				
	As for Zayd, he loved Mayy greatly.								

1.1.2. Verbal Structure

What the grammarians meant by the verbal structure was any structure that begins with the category of M (i.e., M-predicate). Generally, however, M represents the verb constituent which might be a one-, two-, three-, or four-place predicate. The verbal structure consists of the sentential structure: M-MI. The Arab grammarians' concept of the verbal structure can be shown in (7).

(7)	M		MI	
	jāʔa	zaydun		
	came	Zayd		
	Zayd came.			

Any structure which has the order of (7) must be verbal according to their theory. But the syntactic category M might be other than verb. It might be a verbal noun (i.e., gerund) which functions exactly as if it were a verb. Thus any constituent which is capable of assigning these markers can be M category regardless of the nature of that constituent. This can be shown in (8), (9), and (10), where the M is respectively verbal noun, strong verb, and defective verb (i.e., kāna 'was').

'exist.'³ The structure of adverbial sentences can be seen in (11) and (12).

(11) a. $\begin{array}{c} \text{MI} \\ \boxed{\text{zaydun}} \end{array} \quad \begin{array}{c} \text{M} \\ \boxed{\text{fī d - dāri}} \end{array}$
 Zayd in the house
 Zayd is in the house.

b. $\begin{array}{c} \text{MI} \\ \boxed{\text{zaydun}} \end{array} \quad \begin{array}{c} \text{M} \\ \boxed{(\text{yakūnu huwa}) \text{ fī d - dāri}} \end{array}$
 Zayd is he in the house
 Zayd is in the house.

c. $\begin{array}{c} \text{MI} \\ \boxed{\text{zaydun}} \end{array} \quad \begin{array}{c} \text{M} \\ \boxed{(\text{kāna huwa}) \text{ fī d - dāri}} \end{array}$
 Zayd was he in the house
 Zayd was in the house.

(12) a. $\begin{array}{c} \text{MI} \\ \boxed{ʔal-qitālu} \end{array} \quad \begin{array}{c} \text{M} \\ \boxed{l-yawma} \end{array}$
 the fighting today

³Ibn ya^CIṢ stated the following: "You must know that the predicate, if it is a prepositional phrase, is not the real predicate. The adverbial phrase [or the prepositional phrase] is an acted-upon element by the predicate for which it is substituted. The underlying structure is Zaydun (yastaqirru huwa) fī d-dāri. The verb being deleted and replaced by the adverbial phrase and prepositional phrase because they are expressive enough to take the place of the verb semantically," Ibn ya^CIṢ (d. 1250), Ṣarḥ al-mufaṣṣal, Ed. Alam al-Kutub, Beirut, 1970, Vol. 1, p. 90.

b.

MI
ʔal-qitālu

M
(yakūnu huwa) l-yawma

 the fighting is he today
 The fighting takes place today.

c.

MI
ʔal-qitālu

M
(kāna huwa) m-mbāriḥata

 the fighting was he yesterday
 The fighting was yesterday.

As seen in (11) and (12), the verb yakūnu 'is' and its subject must be deleted from the surface structure even though it is present in the underlying structure. Such structures would be reductively nominal (noun initial).

1.1.4. Conditional Structure

Arab grammarians explained another structure, i.e., a conditional structure. This means that the sentence consists of two structures which function as one structure. Any structure which consists of the following formula "If sentence₁, then sentence₂" is a conditional structure. This can be seen in (13).

(13) a.

ʔiōā ^{x-}	ʔanta	ʔakramta	l - karīma	malakta - hu
if	you	honor	the kind person	you own him

b.

wa	ʔin	ʔanta	ʔakramta	l - laʔīma	tamarrada
and	if	you	honor	the evil person	he rebels

(ʔAl-Mutanabbi: poet)

If you honor the kind person you own him and if you honor the evil person he rebels.

The majority of the Arab grammarians assumed two structures, i.e., nominal and verbal structures. They classified the adverbial structures under the nominal structures and they classified the conditional structures under the verbal structures, even though they are different structures such as complex.

Thus, Arabic language consists of two basic structures, one being "nominal" and the other "verbal." These two basic structures can be presented as follows:

- (14) Verbal sentence (M-MI).
- (15) Nominal sentence (MI-M).
- (16) Verb must be deleted in the equational structure except for the verb kāna 'was' in the past, and the verb sayakūnu in the future. But it must be present in the nominal structure (MI-M).

The theoretical classification of the sentential structures in the Arabic theory was based on the nature of the linguistic constituents. If the MI topic is located to the left of the verb, the structure is nominal. If the MI topic, however, is located to the right of the verb, the structure is verbal. This kind of structural differentiation has crucial functional and pragmatic aspects, as we shall see in the following sections.

1.2. The Nature of Kalām as Large and Small

Arab grammarians analyzed the Arabic sentence from another perspective. They studied whether a particular

structure is large 'complex' or small 'simple.' To the best of my knowledge, Ibn Hišām (d. 1368) was the first Arab grammarian who analyzed the Arabic sentence into two types. The first was called kubrā 'large sentence' and the second called ṣuġrā 'small sentence.'

1.2.1. The Kubrā Sentence

Ibn Hišām meant by kubrā any large sentence which consists of more than one sentence.⁴ This means that the kubrā sentence might be a nominal sentence whose structure consists of an MI-topic and an M-comment. The M-comment can be either an equational sentence as in (17), or a verbal sentence as in (18). The kubrā sentence might be a verbal sentence which consists of two verbal clauses, such as in (19). The structures of such sentences can be exhibited in (17), (18), and (19).

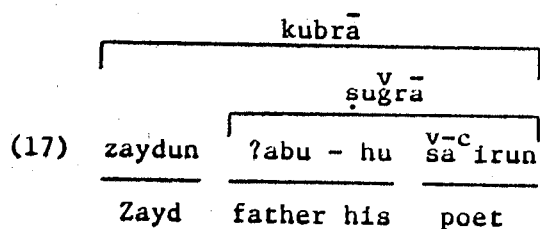

As for Zayd, his father is a poet.

⁴Ibn Hišām stated that, "Kubrā sentence consists of a noun as a topic and either a verbal sentence or a nominal sentence as a comment. Kubrā sentence might consist of two sentences, one of which is dependent and one of which is independent," Ibn Hišām (d. 1368), Muġni L-labīb, Eds. Al-Mubārak, M., and Ḥamadallah, M., Damascus, 1969, pp. 424-425.

- kubrā
- | | | | |
|---------------------|----------------------|-------|----------------------------------|
| kubrā | | | |
| ṣugrā ^{v-} | | | |
| hindun | tugannī ^v | ∅-Pro | ṣi ^v ran ^c |
- (18) Hind sings she poetry
As for Hind, she sings poetry.

- kubrā
- | | | | | |
|---------------------|------------|---------|-------|----------------------------------|
| kubrā | | | | |
| ṣugrā ^{v-} | | | | |
| ʔaṣbaḥa | l - wazīru | yaktubu | ∅-Pro | ṣi ^v ran ^c |
- (19) became the minister write he poetry
The minister became a writer of poetry.

1.2.2. The Ṣugrā Sentence

Ibn Hiṣām meant by ṣugrā sentence any small and simple sentence.⁵ The simple sentence is existential or verbal. The structure of the simple sentence can be seen in (20), (21), and (22).

- ṣugrā^{v-}
- | | | |
|---------------------|------------------------|--|
| ṣugrā ^{v-} | | |
| ʔabū - hu | ṣa ^{v-c} irun | |
- (20) father his poet
His father is a poet.

⁵ Ibn Hiṣām stated that "Ṣugrā sentence is any simple and independent sentence which can be of two kinds: verbal sentence and existential sentence," Ibn Hiṣām (d. 1368), Mugni L-labīb, Eds. Al-Mubārak, M., and Ḥamadallah, M., Damascus, 1969, p. 224.

(21) $\begin{array}{c} \text{v} \\ \text{su} \end{array} \bar{\text{grā}}$

v tugannī	hindun	v^{c} si ^c ran
-----------------------	--------	--

sings Hind poetry
Hind sings poetry.

(22) $\begin{array}{c} \text{v} \\ \text{su} \end{array} \bar{\text{grā}}$

yaktubu	1 - wazīru	v^{c} si ^c ran
---------	------------	--

write the minister poetry
The minister writes poetry.

1.3. The Nature of the Functional Roles of Kalām

Functional roles were discussed in the Arabic theory on two linguistic levels, the sentence level and the word level.

1.3.1. The Functional Role of Sentence

The important perspectives by which Arab grammarians analyzed the Arabic sentence were the functional roles which the sentence might or might not inherit. That is, the sentence might substitute for a certain syntactic element and function exactly as if it were that element. The functional role of certain sentences can be shown in (23), (24), and (25).

(23) a. $\begin{array}{c} \text{sentence} \\ \text{v} \\ \text{yuga} \end{array}$

zaydun	v yugadiru	∅-Pro	v ḡadan
--------	------------------------	-------	---------------------

Zayd leave he tomorrow
As for Zayd, he leaves tomorrow.

- b.

		noun phrase		
<u>zaydun</u>	<u>mugādirun</u>	<u>∅-Pro</u>	<u>gadan</u>	
Zayd	leaving	he	tomorrow	

 As for Zayd, he leaves tomorrow.

- (24) a.

				sentence		
<u>lā</u>	<u>tadxul</u>	<u>∅-Pro</u>	<u>iṣ - ṣaffa</u>	<u>wa</u>	<u>?anta</u>	<u>ḍāḥikun</u>
not	enter	you	the class	and	you	laughing

 Don't enter the class while you are laughing.

- b.

				adverbial phrase	
<u>lā</u>	<u>tadxul</u>	<u>∅-Pro</u>	<u>iṣ - ṣaffa</u>		<u>ḍāḥikan</u>
not	enter	you	the class		laughing

 Don't enter the class while you are laughing.

- (25) a.

			sentence		
<u>māta</u>	<u>^camrun</u>	<u>yawma</u>	<u>wulida</u>	<u>zaydun</u>	
died	^c Amr	day	born	Zayd	

^cAmr had died on the day Zayd was born.

- b.

			noun phrase	
<u>māta</u>	<u>^camrun</u>	<u>yawma</u>	<u>mīlādi</u>	<u>zaydin</u>
died	^c Amr	day	birth	Zayd

^cAmr died on the day Zayd was born.

In (23a), (24a), and (25a), sentences occur in the same positions as their sentential noun phrase or adverbial phrase counterparts in (23b), (24b), and (25b). In (23a), the sentence functions as if it were a predicate; in (24a), the sentence functions as if it were a participial complement of manner (i.e., AdvP); and in (25a), the sentence functions as

if it were a clause modifying an adverb. This means that one structural position can hold two syntactic categories and bear the same semantic role. Let us consider the following example, where the sentence does not have a functional role.

(26) hal ʔadullukum ʕalā mustaqbalin bāhirin :
 Q I guide you on future successful:

sentence

tadrusūna	l-lisāniyyāt	?
-----------	--------------	---

you study linguistics

Do I guide you to a successful future? I.e., study linguistics.

In the above sentence, the independent sentence cannot be replaced by a noun phrase and inherit its syntactic and semantic properties.

Arab grammarians investigated the functional role of the sentences in depth, especially Ibn Hišām^{V-}. Thus the investigation of this phenomenon in depth is beyond the scope of this study.

1.3.2. The Declensional Role of Word

Arabic, like Latin, is an inflected language that has what is called ʔal-ʔi^Crāb (i.e., declension), which means the marking of syntactic cases on the lexical items. This can be seen from the following examples.

(27)* mā ?aḥsan zayd (uninflected string)

- a. mā ?aḥsan-a zayd-an
 how nice [exclamation] Zayd [+acc]
 How nice Zayd is.
- b. mā ?aḥsan-a zayd-un
 not did well [verb] Zayd [+nom]
 Zayd did not do well.
- c. mā ?aḥsan-u zayd-in ?
 what better [+nom] Zayd [+gen]
 What is best in Zayd?

As seen from the above examples, the case markers assigned to the constituents give three different semantic readings.

Markers in Arabic are assigned to nouns and verbs. When they are assigned to nouns, they will be called "case markers." When they are assigned to verbs, they will be called "mood markers." I shall be concerned here with the case markers of the nouns. Mood markers of the verbs, however, are not treated here.

1.3.2.1. The Syntactic Markers of the Nouns

The major markers assigned to nouns can be seen in the following chart.

Case Marker	Uninflected Noun	Inflected Noun
1. Nominative (u)	wazīr 'minister'	wazīr-u (n)
2. Accusative (a)	bayt 'house'	bayt-a (n)
3. Genitive (i)	walad 'boy'	walad-i (n)

The nominative marker is assigned to the noun when it is in a subject position. For example:

- (28) ja?a r-rajul-u
 came the man
 The man came.

The accusative marker is assigned to the noun when it is in an object position. For example:

- (28) madha l-mutanabbi l - ?amir-a
 praised ?Al-Mutanabbi the prince
 ?Al-Mutanabbi praised the prince.

The genitive marker is assigned to the noun when it is in a prepositional phrase of any type of non-initial position in a possessive phrase. For example:

- (30) marar-tu bi zayd-in
 passed I by Zayd
 I passed by Zayd.
- (31) qara?tu kitaba zayd-in
 read I book Zayd
 I read Zayd's book.

There are some situations, however, where the case markers discussed above do not apply. This can be seen in the six irregular nouns, the dual nouns, the plural nouns, the non-inflected nouns, and the pronouns.

2. The Syntactic and Semantic Notions in the Sentential Structures

In this section, I shall explain the syntactic and semantic notions as understood by the early Arab grammarians. The explanation of syntactic and semantic notions will be helpful in understanding the simple basic structures in Arabic as we shall see in Chapter Three.

2.1. Syntactic Notion

The concepts of musnad (M), musnad ?ilayhi (MI), and faḍlah (henceforth F) (i.e., syntactic and semantic adjunct) were the cornerstone of the basic sentence in the Arabic theory. The majority of the Arab grammarians built their syntactic analysis on these three categories of which the Arabic sentence consists. The relation which holds among these three categories is called ?isnād (IS), i.e., predication.

Sībawayhi (d. 793) was the first Arab grammarian who tried to explain the relations which hold among these structural categories. But Sībawayhi did not describe them in very much detail; this was left for the grammarians who came after him and explained his work.

The most important explanation and clarification of the configurational structures is found in the work of the "rhetoricians," as we shall see in the work of ?al-Jurjāni (d. 1078) particularly. But as far as the explanatory work of

Sībawayhi is concerned, the most important and profound explanation was done by Ibn ya^{cī}š (d. 1250) who came four hundred years after Sībawayhi. Ibn ya^{cī}š tried to go deeper than Sībawayhi in explaining in detail the theoretical framework of the structures of the basic sentence. The argument of Ibn ya^{cī}š was that every M must be adjacent to its subject MI. The MI-subject might be overt or it might be covert. If the MI subject is overt, it must be adjacent to the right of the verb. If it is covert, however, the M-verb must operate on a resumptive pronoun which is either covert or overt. Ibn ya^{cī}š, however, explained such syntactic relations by citing the following examples:

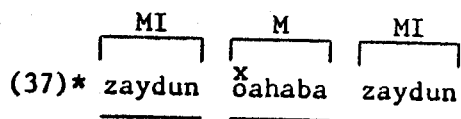
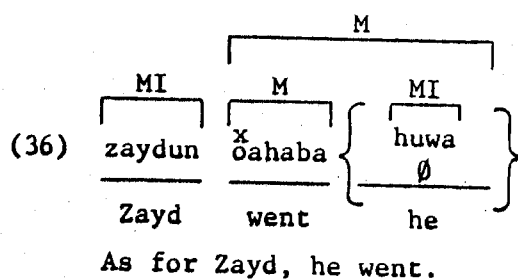
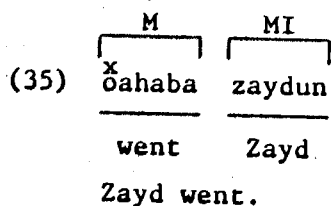

The argument here is that in (35) the structure represents the normal relations of the basic sentence. In (36), the MI

precedes the M, but the M must be adjacent to the resumptive pronoun of the preceding MI-topic. In (37), the MI cannot be adjacent to the right of its verb, since it is the topic of the sentence.

Arab grammarians considered the subject or fā^cil constituent to be a part of the verb: that is, adjacent to its right. The verb and its subject are dominated by IS predication. The IS, however, is dominated by K, 'sentence,' only when the predication produces an independent meaningful sentence.⁶

The structural relations of the sentence can be shown in (38a) and (38b).

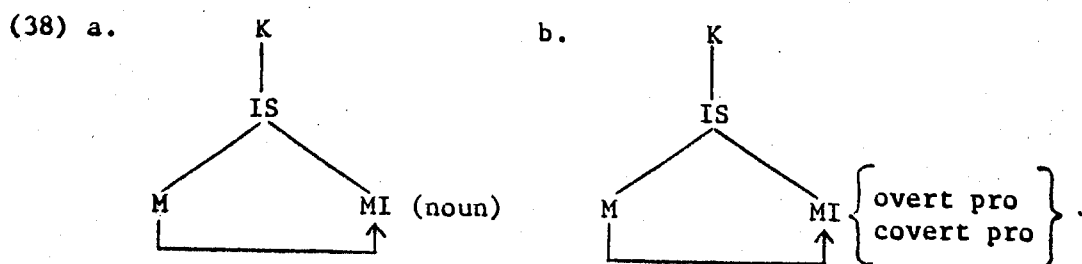

In the Arabic theory, all constituents which are not M or MI were considered to be what they called fadlah (F).

⁶Ibn ya^ci^v stated that "every Musnad 'predicate' must be adjacent to Musnad ?ilayhi 'subject.' The relation holding between the predicate and its subject is called Isnād 'predication,' i.e., the combination of the predicate to its subject. This predication might or might not produce a meaningful independent sentence. When such a predication produces a meaningful independent sentence, it will be Kalām 'sentence,'" Ibn ya^ci^v (d. 1250), Ṣarḥ al-mufaṣṣal, Ed., Alam al-kutub, Beirut, 1970, Vol. 1, p. 74.

i.e., adjunct. Note that the concept of fadhlah in the Arabic perspective does not mean that the F-constituent can be discarded from the structure of IS. What is meant is that the F-constituent is not a part of the unity holding between M+MI. According to the syntactic notion in the Arabic theory, all constituents must be organized by syntactic notions such as particles except the initial constituents on the verbal and nominal structures, i.e., initial MI and M which are assumed to be organized by an abstract notion of what the Arab grammarians called cāmil ?al-?ibtidā?iyyah, i.e., nominal notion, and cāmil ?al-fā?iliyyah, i.e., verbal notion. The verbal notion will organize the verbal structure such as in (39).

(39)	M		MI		F
	?intaqada		zaydun		?al - wazīra
	criticized		Zayd		the minister
	Zayd criticized the minister.				

The nominal notion, however, will organize the nominal sentence as in (40).

(40) a.	M		
	MI		MI
	zaydun		?abū - hu
	Zayd		father his
	As for Zayd, his father came.		

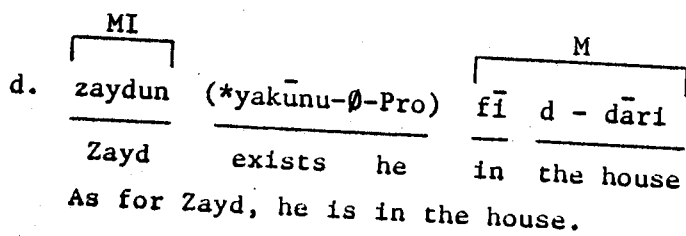
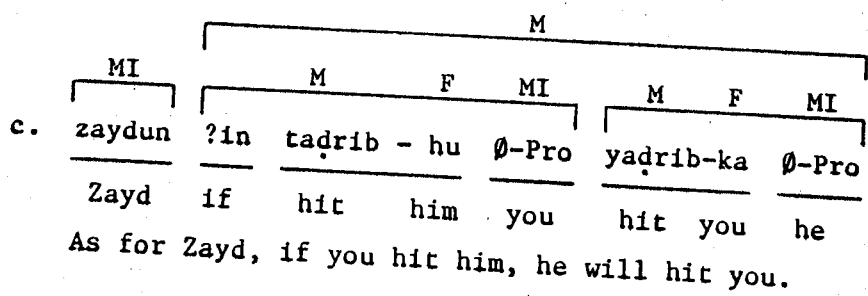
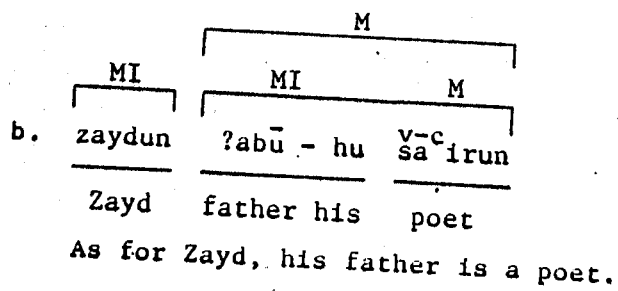

As seen in the above examples, the sentential predicate is accompanied by a resumptive pronoun. Ibn ya^cis stated that the structure of the nominal structure must meet the following conditions:

- (41) a. The MI must be followed by either a verbal sentence as in (40a), or a nominal sentence as in (40b).
 b. The sentential predicate must have either an overt pronoun or a covert pronoun.
 c. The resumptive pronoun must be coreferential with the MI.
 d. Or otherwise, nominal structures will violate the syntactic notion of the sentence.

The crucial notion in the Arabic theory is the notion of ʔal-^camil wa l-^cmūl, i.e., a certain operator (such as a

particle) and the element acted upon (such as a noun or verb), which are considered one linguistic unit. Thus if the acted-upon element is not an overt pronoun, it must be a covert pronoun. From this point of view, Arab grammarians proposed that if we have a sentential structure which consists of one constituent (i.e., the verb) as in (42a), the syntactic relations of such structure would be as in (42b).

(42) a. ?akala

ate

He ate.

b. ?akala [covert pronoun (\emptyset -Pro)]

ate

he

This means that the M which is a verb in (42b) operates on a covert pronoun which is a subject in this case.

The main theoretical insight here is that Arab grammarians analyzed the Arabic sentence from a relational point of view, because of the nature of ?al-^Camil wa l-^Cma^Cmūl.

2.2. Semantic Notion

As seen before, the most important categories of the Arabic structure are M and MI. When the structural relation is established between these two essential categories by the domination of the IS-node, the structure can accept syntactic and semantic extra categories (i.e., F, or particles of question, negation, etc....). The syntactic structure of such essential categories has a systematic word order as in (43) and (44).

particle) and the element acted upon (such as a noun or verb), which are considered one linguistic unit. Thus if the acted-upon element is not an overt pronoun, it must be a covert pronoun. From this point of view, Arab grammarians proposed that if we have a sentential structure which consists of one constituent (i.e., the verb) as in (42a), the syntactic relations of such structure would be as in (42b).

(42) a. ʔakala
ate
He ate.

b. ʔakala [covert pronoun (∅-Pro)]
ate he

This means that the M which is a verb in (42b) operates on a covert pronoun which is a subject in this case.

The main theoretical insight here is that Arab grammarians analyzed the Arabic sentence from a relational point of view, because of the nature of ʔal-^Cāmil wa l-^Cma^Cmūl.

2.2. Semantic Notion

As seen before, the most important categories of the Arabic structure are M and MI. When the structural relation is established between these two essential categories by the domination of the IS-node, the structure can accept syntactic and semantic extra categories (i.e., F, or particles of question, negation, etc....). The syntactic structure of such essential categories has a systematic word order as in (43) and (44).

(43) [M.....MI.....F]

(44) [MI.....M.....F]

These main word orders which result in two semantic structures were emphasized by the majority of the Arab grammarians. They also allowed these two systematic word orders to be flexible and exhibit varieties of structures under certain conditions. In fact, the semantic and functional roles which these structures reveal were not clear enough in the work of the Arab grammarians, because they were interested in a purely syntactic analysis of the Arabic language. It was those who were called in the Arabic tradition "rhetoricians" who explained exhaustively and elaborately the functional aspects of these basic structures. ?Al-Jurjāni, for example, explained, among many things, the structural flexibilities of the Arabic language which are a result of different word order. ?Al-Jurjāni explained the syntactic phenomenon of preposing and postposing constituents to the right or to the left of the verb. This phenomenon reveals the systematic aspects of the semantic roles of the Arabic sentence.

?Al-Jurjāni proposed two types of preposing constituents in the basic sentence. The first type he called taqdīm ^calā niyyati t-ta?xīr, i.e., preposing with the intention of postposing. The second type he called taqdīm lā ^calā niyyati t-ta?xīr, i.e., preposing with no intention of postposing.

Let us consider the following examples cited by ?Al-Jurjāni.

(48) a. zaydun ?al-muntaliqu
 Zayd the departer
 Zayd is the departer.

b. ?al-muntaliqu zaydun
 the departer Zayd
 The departer is Zayd.

As seen in the above examples, the structure has an initial constituent as the topic of the sentence either in the nominal verbal structure as in (47b), or in the nominal equational structure as in (48b). Initiating constituents either intentionally or unintentionally reflects a presupposition on the part of the speaker, because the fronted constituent in either case serves as a focus.

These systematic principles of the presuppositional semantics which ?Al-Jurjāni tried to establish can be clarified through the following examples.

(49) a. ?a ^camrun ḍaraba ∅-Pro zaydan ?
 Q ^cAmr hit he Zayd
 Is it ^cAmr who hit Zayd?

b. ^camrun ḍaraba ∅-Pro zaydan
^cAmr hit he Zayd
 It is ^cAmr who hit Zayd.

(50) a. ?a zaydan ḍaraba ^camrun ?
 Q Zayd hit ^cAmr
 Is it Zayd that ^cAmr hit?

- b. zaydan daraba ^camrun
 Zayd hit ^cAmr
 It is Zayd that ^cAmr hit.
- (51) a. ?a rākiban jā?a zaydun ?
 Q riding came Zayd
 Is it by riding that Zayd came?
- b. rākiban jā?a zaydun
 riding came Zayd
 It is by riding that Zayd came.
- (52) a. ?a jā?a rākiban zaydun ?
 Q came riding Zayd
 Did Zayd come by riding?
- b. jā?a rākiban zaydun
 came riding Zayd
 Zayd came by riding.
- (53) a. ?a fī d - dāri zaydun ?
 Q in the house Zayd
 Is it in the house that Zayd is?
- b. fī d - dāri zaydun
 in the house Zayd
 It is in the house that Zayd is.
- (54) a. ?a munṭaliqun zaydun ?
 Q departed Zayd
 Has Zayd departed?

b. muntaliqun zaydun
 departed Zayd
 Zayd has departed.

(55) a. ?ā l - muntaliqu zaydun ?
 Q the departer Zayd
 Is the departer Zayd?

b. ?al-muntaliqu zaydun
 the departer Zayd
 The departer is Zayd.

The most important semantic function of the initial constituents in (49b-55b) is to convey concentrated semantic information which is very important to the speaker-hearer's communicative knowledge. And as we have seen, even though the structural process is different in fronting these constituents (i.e., preposing with or without intention of postposing), the semantic process is identical. They convey the same semantic information which is considered to be "focus," "interest," or "importance" in ?Al-Jurjāni's terminology. The virtue of ?Al-Jurjāni, however, was that he tried to seek a more comprehensive explanation of this phenomenon. It was not enough for him to say that the initial constituents serve as focus only. He went beyond such an explanation to establish a presuppositional semantic system by which we can figure out the nature of the fronted constituents, as seen in (49-55).

The fact that different structures in sentence initial position have general semantic structure was captured by

Ibn Jinni (d. 1002). Ibn Jinni considered the verbal structure and the nominal structure to be identical semantically, even though they are different syntactically, because the MI constituent is fronted to the left of the M constituent for focus. Ibn Jinni gave these two examples:

(56) qāma zaydun
 stood up Zayd
 Zayd stood up.

(57) zaydun qāma ∅-Pro
 Zayd stood up he
 As for Zayd, he stood up.

In the structure (56), the MI-subject is to the right of the verb. In structure (57), the MI is to the left of the verb, but semantically they have one general meaning, i.e., "Zayd stood up." Ibn Jinni fully knew that syntactically the MI-subject never precedes its verb. But for a focus function, one can initiate the MI in front of the verb and replace it by damīr mustatir (i.e., covert pronoun) which must be adjacent to the right of the M.

This suggests that Arab grammarians and linguists distinguished between two types of semantic structures. The first type was a general semantic notion: we have different syntactic structures with one general semantic structure (Ibn Jinni). The second type was a specific semantic notion: We have different syntactic structures which bear different specific semantic functions (?Al-Jurjāni).

In short, Arab grammarians proposed three constituents, namely, MI 'topic' and 'subject,' M 'predicate,' and F 'adjunct.' The relation holding among these constituents (i.e., M - MI = intransitive structure, M - MI - F = transitive structure) is IS predication. When such constituents are organized, the outcome is K 'sentence.' The structure of K is subject to different transformations which produce various general and specific meanings.

CHAPTER TWO

TRANSFORMATIONAL GENERATIVE GRAMMAR THEORY

0. Introduction

In the early work of Transformational Generative Grammar (henceforth TGG), linguists were interested in developing transformational rules in order to capture the syntactic properties linking underlying language structures to surface structures. Generative grammarians in the last decade tried to constrain the power of transformational rules (Perlmutter, 1971; Emonds, 1976; Chomsky, 1977). Moreover, they have been trying to eliminate some of these rules. They are seeking a more abstract system of principles which govern the operation of syntactic and semantic domains.

The following theories of TGG illustrate the shift in the recent work.

- (1) The Syntactic Theory of 1957
- (2) The Standard Theory of 1965
- (3) The Extended Standard Theory
- (4) The Thematic Relations (Gruber/Jackendoff)
- (5) The Case Grammar Theory (Cook)

In this chapter, I shall be concerned with theories which have been modified semantically. The semantic development will be investigated with a view to the reasons which made Chomsky revise his theories, and with a view to the efforts which were made by Gruber (1965) and Jackendoff (1972-1976)

who tried to broaden the semantic concepts of TGG. The chapter will investigate independently the case grammar which was developed by Cook (1979). The ultimate goal of such semantic development is to reach a satisfactory semantic framework to describe and explain the sentential structures in Arabic.

1. The Syntactic Theory of 1957

In his 1957 theory, Chomsky did not incorporate any semantic level. This theory was formalized on the basis of purely syntactic dimensions which consisted of three levels:

- (a) The phrase structure level, in which rules rewrite individual symbols in order to produce strings represented by a configurational tree diagram. This level operates with two rules: (1) branching rules, and (2) lexical rules. The function of these rules is to take the initial symbol #s# as an input and change it to a terminal string as an output.
- (b) The transformational level consists of two sets of rules: (1) optional rules, and (2) obligatory rules. This level operates on the terminal string as an input. If the obligatory rules are operating alone, the output will be a kernel sentence. If the optional and obligatory rules are operating, the output will be a derived sentence.
- (c) The morphophonemic level, which consists of morphophonemic rules. The function of these rules is to convert either the kernel or the derived sentence as an input into the final form.

It seems, from the Syntactic Theory of 1957 presented above, that Chomsky did not incorporate the semantic component in his model. It was Katz and Fodor (1963) who raised that question. Katz and Fodor attempted to develop semantic theory within TGG. Moreover, they wanted to investigate the question of semantic comprehensiveness within the whole phenomenon of human languages. Specifically, however, they introduced two semantic rules known as (1) lexical rules, and (2) projection rules. The function of the lexical rules was to characterize the lexical items and their functions in the sentence. The function of the projection rules was to determine the way in which the lexical items are combined to interpret the sentence. Projection rules, however, assign semantic interpretation to the phrase markers generated by the base, and they show the way the phrase markers and transformations contribute to the meaning of the sentence.

But Katz and Fodor's semantic theory could not account for a large class of counterexamples. Moreover, their theory was not strong enough to correlate the semantic component with the syntactic component. It was Katz and Postal (1964) who strengthened that connection by introducing a new notion of projection rules and meaning--preserving transformation and specifying adequately the relationships between the semantic component and the syntactic component.

2. The Standard Theory of 1965

Katz, Fodor, and Postal's development of a semantic theory within TGG motivated Chomsky to fill the semantic gap in the Syntactic Theory of 1957. Trying to fill that gap, Chomsky incorporated the developed semantic theory of Katz, Fodor, and Postal into the 1965 Theory. The new modification came to be known as "Standard Theory" and consisted of three levels:

- (a) The syntactic level, which is generative. This level operates on two components: (1) the base component, which consists of three rule types: (a) branching rules, (b) subcategorization rules, and (c) the lexicon; and (2) the transformational subcomponent, which consists of two rule types: (a) obligatory rules and (b) optional stylistic rules. The base generates the deep structure, which has all the meaning. The deep structure is converted into surface structure by transformational rules which are meaning-preserving rules: i.e., they do not change the meaning of the sentence. The transformational rules have the power of adding, deleting, substituting, or moving elements.
- (b) The semantic level, which is interpretive, operates on the deep structure. The semantic component assigns deep structures semantic readings by projection rules which combine the meanings of different elements to produce a semantic representation. The most important innovations in the Standard Theory are the deep structure and semantic representation.
- (c) The phonological level, which is interpretive. It operates on the surface structure of the sentence

using phonological rules to produce a phonological representation or expression.

The Standard Theory of 1965 was accepted by many linguists. But after investigating the nature of semantic interpretation, many came to the conclusion that the semantic component is not capable of accounting for many examples. They claimed that the deep structure is not adequate enough to explain the nature of semantic relations in the sentence. Their arguments arose from various facts. They argued that deep structure cannot explain sentences of different surface structures having one abstract semantic structure as in (1) and (2) (Lakoff, 1970).

- (1) Seymour sliced the salami with a knife.
- (2) Seymour used a knife to slice the salami.

They argued, too, that deep structure cannot determine the correct semantic structure for an ambiguous sentence such as (3) (Lakoff and Peters, 1969).

- (3) John and Mary left.

We do not know whether (John and Mary) left together, at one time, or (John) and (Mary) left separately, at different times.

The most important arguments against deep structure came from two related schools known as "Generative Semantics" and "Case Grammar" (Smith and Wilson, 1979). Linguists working in Generative Semantics, namely, McCawley (1976), Lakoff (1970), and Cook (1980), argued that deep structure is not

deep enough to capture the semantic differences of the sentences, especially those associated with negation and quantifiers. Thus sentences such as (4) and (5) have more than one semantic structure contrary to what was proposed by Standard Theory.

- (4) John did not buy many books.
- (5) Many books were not bought by John.

The difference between these two sentences is "that sentence (4) is contradicted by the statement (John bought many books), whereas sentence (5) is not contradicted by the statement (John bought many books)" (Cook, 1980:V). Linguists working in Case Grammar, namely, Fillmore (1968-1977), Chafe (1970), and Cook (1979), argued that deep structure cannot capture the semantic differences in sentences such as

- (6) The door opened.
- (7) John opened the door.
- (8) The wind opened the door.

The NPs the door in (6), John in (7), and the wind in (8) have different semantic relations to the verb. The Standard Theory, however, considered all these NPs as a subject in the deep structure. Case Grammarians argued that the verb is the central element in these sentences, and has an obligatory theme, the door, with an optional agent, John, or instrument, the wind. Case Grammarians solved this problem by proposing what they called the thematic hierarchy (Gruber, 1965) or case hierarchy (Fillmore, 1968, and Cook, 1979). Case Grammarians

demonstrated another problem with deep structure, which was that deep structure cannot specify the semantic relations between two morphological reciprocal pairs such as

- (9) buy _____ sell
- (10) like _____ please
- (11) see _____ show
- (12) learn _____ teach

A deeper level, for Case Grammarians, treated such verbs as pairs related semantically. They are related by similar source-goal notions but differ as to which is Agent (9), by different subject choice (10), and by the introduction of the element CAUSE (11-12) (Cook, 1979).

Jackendoff (1972) considered some components of the 1965 theory not to be comprehensive, because some projection rules can optionally change the meaning. The result is two semantic interpretations for one sentence. Thus, the Katz-Postal hypothesis, for Jackendoff, is inadequate, because it cannot explain certain negative sentences. Some active sentences, when transformed to negative or passive, do change meanings, as seen in (4) and (5).

But the most important defect of the Katz-Postal hypothesis for Jackendoff is that it is "too weak" in that it fails to constrain the class of possible grammars sufficiently; and at the same time it is "too powerful, in that it defines too large a set of grammars" (Jackendoff, 1972:12). Instead, Jackendoff proposed a new thematic model which is neither "too

powerful" nor "too weak." (For details, see Section 4 of this chapter.)

3. The Extended Standard Theory

As seen before, the most serious problems of the Standard Theory, according to its critics, were two:

- (1) The insufficient depth of deep structure; and
- (2) The inadequacy of the Katz-Postal hypothesis.

These two semantic problems motivated Chomsky again to modify his theory of 1965 with a series of hypotheses and assumptions. We can trace such semantic modifications from the birth of Extended Standard Theory (1970) to more recent semantic modifications.

3.1. The Lexicalist Theory

Chomsky (1970) explored the semantic problem and expressed the need for a more developed semantic component to simplify the TGG. By enriching the semantic component, Chomsky aimed to solve some difficulties concerning nominalization in English, specifically, gerundive and derived nominals. In the Standard Theory, gerundive nominals are assigned semantic readings by the grammatical relations assigned to the underlying positions in the deep structure. However, Chomsky extended the base rules to adopt the derived nominals. He called this modification "the Lexicalist hypothesis" as opposed to the "Transformational hypothesis." The problem which faced Chomsky was that in the case of gerundive nominals, one can transform the structure (13) to (14) as in

(13) John amused the children with his stories.

(14)* John's amusing the children with his stories....

But one cannot do the same thing in the case of derived nominals (15)

(15)* John's amusing of the children with his stories...

This fact led Chomsky to conclude that the transformational hypothesis is insufficient to account for derived nominals, because these nouns are not derived transformationally from the verb. They must be entered in the lexicon. Chomsky developed instead a lexical approach which is more adequate to account for derived nominals and to reduce the semantic ambiguity which surrounds both gerundive and derived nominals. Thus, complex NPs are not derived transformationally, but rather are generated in the base. Chomsky concluded that "derived nominals should have the form of base sentences, whereas gerundive nominals may in general have the form of transforms" (Chomsky, 1970:212). Chomsky suggested that the feature [+ cause] as in (16) can be assigned to certain verbs as a lexical property

(16) John grows tomatoes.

a. John [+ cause] [_S tomatoes grow]_S

b. John [+ cause, grow] tomatoes.

Chomsky suggested also some universal rules which specify that intransitives with the feature [+ cause] will become

transitive. Chomsky's "lexical hypothesis," then, can account for the semantic structure of nominals in different ways

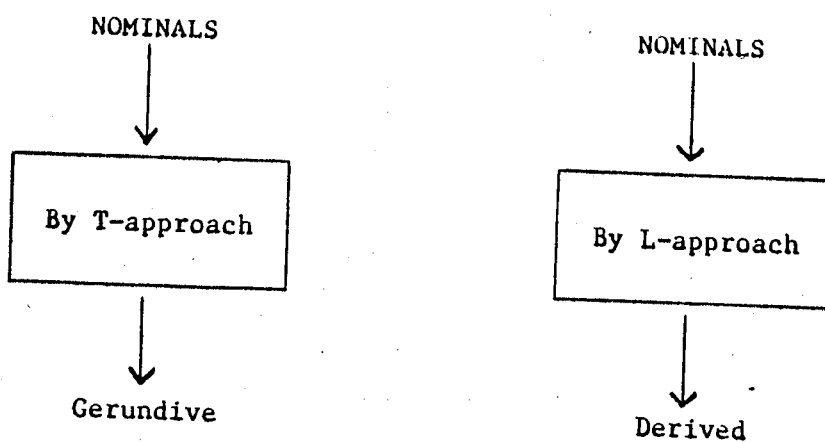

John's refusing the offer.

John's refusal of the offer.

This modification led Chomsky to believe that certain syntactic facts can be captured if the deep structure is less abstract than that of 1965.

3.2. The Interpretive Theory

Chomsky (1971) was dissatisfied again with the Standard Theory because there were other problems which it could not cope with. These problems can be summarized briefly here

(a) The Standard Theory could not explain the semantic structure of focus and presupposition in sentences such as (17) and (18)

(17) Is it JOHN who writes poetry?

(18) It is not JOHN who writes poetry.

These sentences must be interpreted by the surface structure, not the deep structure as proposed by Standard Theory because

"The semantic representation of (17-18) must indicate, in some manner, that 'John' is the focus of the sentence and that the sentence expresses the presupposition that someone writes poetry" (Chomsky, 1971:199).

(b) Standard Theory could not interpret the underlying structure of sentences such as (19) and the derived (20) and (21).

(19) Not [many arrows hit the target]

(20) Not many arrows hit the target.

(21) Many arrows did not hit the target.

Thus the relative positions of the negative and quantifiers assign the structure different meanings, as shown in (20) and (21). Chomsky concluded that negation and quantifiers must be interpreted at the surface structure.

(c) The modal "shall" must be interpreted by the surface structure, because "shall" in questions is different from that in declarative sentences semantically. "Shall" in (22) and (23) has different semantic structures.

(22) I shall go home.

(23) Shall I go home?

In (22) "shall" is a tense marker, but it has the meaning of "should" in (23).

(d) In anaphoric structure, the semantic interpretation operates on the surface structure, because of the stress rule, as in (24).

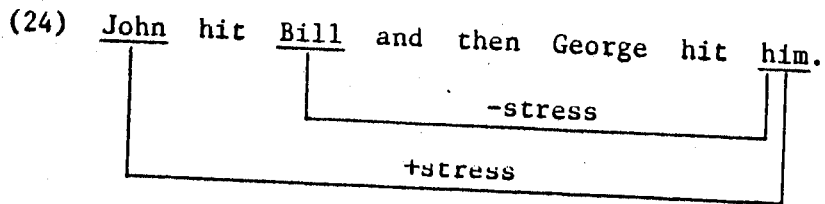

In this sentence, the pronoun (him) refers to (Bill) if it is unstressed, but it refers to (John) if it is stressed.

(e) Perfect aspect has an important role in determining semantic interpretation. For example, sentence (25).

(25) John has lived in Cambridge.

entails that John is alive. For, if the statement (26) is true,

(26) Bill is dead.

then the sentence (Bill has lived in Cambridge) is at least misleading. The correct structure is (Bill lived in Cambridge).

To cope with these difficulties, at this point Chomsky related semantic representation to deep structure and surface structure by introducing two types of projection rules, #1 for deep structure and #2 for surface structure interpretation. Semantic interpretation in this modification operates at surface structure and deep structure. In addition, Chomsky dropped what is called the "Katz-Postal hypothesis" which claimed that transformations do not change meaning. In this interpretive theory, however, transformations may change meaning.

3.3. Recent Syntactic and Semantic Modifications

After the formalization of the lexicalist and interpretive theories, the work in TGG began to restrict the power of transformational rules and to put certain constraints on them, such as the constraints on extraction, structure-preservation, anaphora, and those applying to base and surface structure (Emonds, 1976). Emonds (1976) discussed some constraints on phrase structure, root transformation, structure-preserving transformations, and adjectival and prepositional phrases. But the most important restrictions and constraints are those discussed by Chomsky (1973-1977) and Chomsky and Lasnik (1977). Chomsky called for autonomous cognitive structures which are interactive systems of phonetic, phonological, morphological, and syntactic rules and which comprise what he called "logical form." The interaction among these levels is carried out by the same components of the Standard Theory, namely the syntactic component (base and transformational rules), semantic component (projection rules), and phonological component (phonological rules).

The modifications of 1973-1977 indicate a balance of syntax and semantics. This balance can be seen from the fact that some syntactic concepts have been changed in favor of semantics.

The most recent work of Chomsky's (1981) is aimed at unifying all theories modified from 1970-1981. This theory represents a more comprehensive version of TGG. By unifying

the sub-theories in one theory, TGG can describe the conceptual and empirical levels in human language. The new version of TGG is shown in Figure 1.

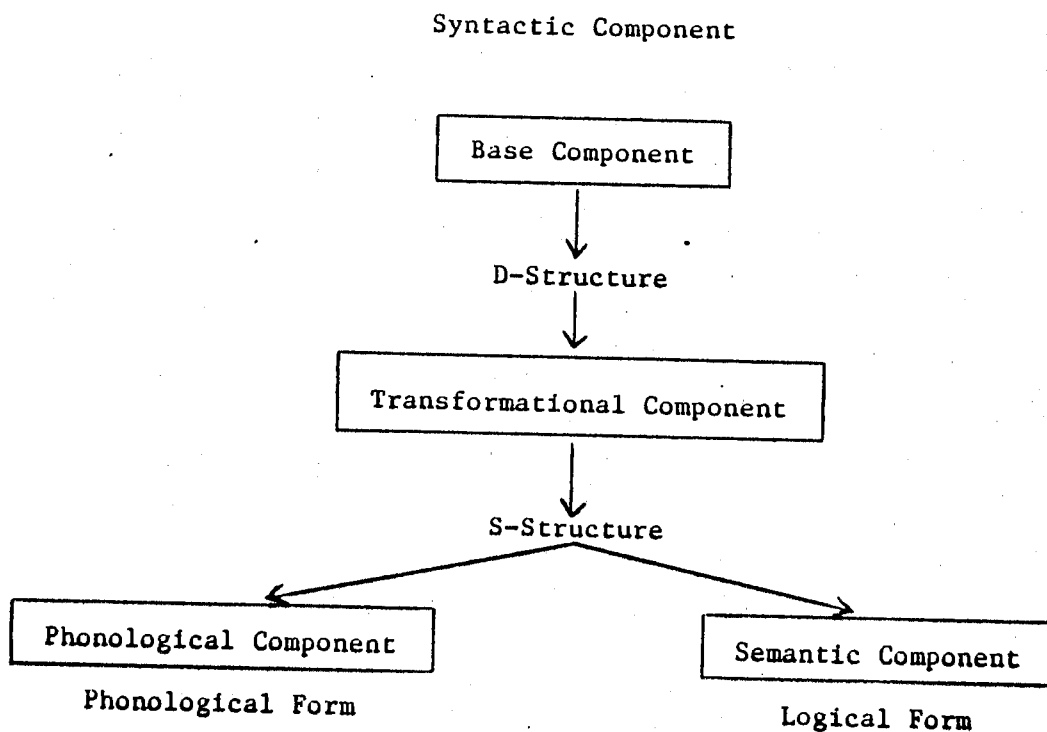

FIGURE 1. NEW VERSION OF TGG, CHOMSKY (1981:17)

4. Jackendoff's Syntactic-Thematic Model

Before exploring the model of Jackendoff (1972), which is based on Gruber's thematic theory (1965), it would be helpful to explain briefly the general principles of thematic theory.

4.1. The Thematic Theory of Gruber

The justification of thematic theory in Gruber's viewpoint (1965) was the semantic difficulties encountered by TGG. The connection of the semantic component with the syntactic

component was weak enough that TGG needed such modification. Gruber proposed what he called the "prelexical derivational system," which could represent an independently generated lexical item with a complete set of syntactic, semantic, and phonological markers. In the proposed theory, Gruber investigated the syntactic and semantic relations in the basic sentence, and the rules which organize such relations. The prelexical rules, for example, determine the syntactic ordering of the sentence. The environmental-thematic specification rules will determine the semantic readability of the sentence. In this sense, the derivational semantic system in Gruber's view will be somewhat deeper than the deep structure of Chomsky (1965). Prelexical structure in thematic theory will be generated before any syntactic and semantic interpretation. Structural connections between the elements of the sentence will determine the syntactic interpretation. Environmental specification of the elements will determine the semantic interpretation. The structural connections incorporated with the environmental specification will produce the basic sentence.

The most important idea in Gruber's theory is that thematic roles are given in the basic sentence. Gruber's list of thematic roles includes the following: (a) Theme, (b) Location, (c) Source, (d) Goal, and (e) Agent. Theme is a central obligatory element of the situation generated in the prelexical structure, as in (27).

(27) The rock rolled down the hill.

Location is expressed by physical or abstract (psychological) notion as in (28) and (29):

(28) John stayed in the room.

(29) John stayed angry.

Source and Goal can be expressed physically or abstractly as in (30) and (31).

(30) John went from Washington to Cambridge.

(31) John went from elated to depressed.

Gruber proposed two types of agent: the first is called Causative agent as in (32), the second is called Permissive agent as in (33).

(32) John hit Bill.

(33) Let the bird escape.

In general, Gruber's theory dealt with the prelexical structure of verbs. He believed that by decomposing some verbs into one of several category strings, verb + Prep, verb + Prep + NP, etc., he could explain the meaning of the verb (e.g., a preposition could not occur if it was already incorporated). Verbs were then introduced from the lexicon, and by polycategorical attachment--one verbal item taking the place of various category strings--he could introduce the verb into the structure.

If verbs could be thus decomposed, then in the generation of the sentence the underlying categories could

be generated in the base, and then several lexical categories, including the verb and other elements could be replaced by a single verb when lexical insertion applied. It was slightly deeper than the DS of Standard Theory in decomposing the verb.

Gruber's real contribution was probably the thematic role structure which he used to defend his lexical decompositions, and which constituted, in effect, the first case grammar.

4.2. The Syntactic-Thematic Theory of Jackendoff

Jackendoff (1972:14-17) proposed a new semantic model based partly on Gruber's thematic relations. Jackendoff incorporated the new semantic model within the TGG of Chomsky. The semantic model of Jackendoff consists of four semantic structures:

- (a) The functional structure: which represents the thematic relations among elements in the basic sentence, such as the relations among verb and roles (theme, location, source, goal, and agent).
- (b) The modal structure: which specifies different semantic conditions such as (1) coreference, (2) genericity, (3) referential opacity, and (4) illocutionary force.
- (c) The table of coreference structure, which indicates whether two NPs in sentences have anaphoric structure or not, as in (34) and (35).

(34) John hit himself.



(35) John hit him.

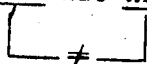

- (d) The focus and presupposition structure, which indicates the new and old information in the basic sentence. This structure is introduced by emphasis, stress, or intonation. For example, (36) and (37) are different.

(36) JOHN saw Bill.

(37) John saw BILL.

The four structures will assign semantic interpretation to the elements in the sentence, but they cannot assign a well-formed connection within the sentence. Jackendoff (1972:25) proposed three rules, namely: (a) selectional restrictions, (b) consistency condition on coreferents, and (c) thematic hierarchy condition. Jackendoff thought that TGG in its standard version could not capture the semantic relations among these sentences.

(38) The door opened.

(39) John opened the door.

(40) Fred bought some hashish from Reuben.

(41) Reuben sold some hashish to Fred.

Jackendoff's semantic model, however, can capture such relations. The NP the door has the same thematic function in (38) and (39), although it is the subject in one

sentence and the object in the other. The same relations hold between (40) and (41). In (40), the NP Fred is the subject and Reuben is in a prepositional phrase, and the reverse holds in (41). But Fred in both (40) and (41) has identical thematic roles and the same holds for Reuben. Thus, in Jackendoff's model, the NP the door in the deep structure will have the same case role in (38) and (39), namely, theme, in DS. The NPs Fred and Reuben would have the same semantic relations in (40) and (41). But Fred is Agent and Goal in (40), Reuben is Agent and Source in (41).

The connection between Jackendoff and Gruber is that Jackendoff adopted Gruber's whole thematic system, without change, and used it for semantic interpretation (1972, SIGG). Thus in (38) there is no agent, but if we change the sentence to (39), it will be John who opened the door. John is functioning as an agent, but in (38) the subject the door is the theme. The subject John in (39) is the agent, and the object the door is still the theme. By the same thematic notion, Jackendoff analyzed sentences (40) and (41). In (40) the subject Fred is functioning as the goal and Reuben is functioning as the source. We will have the same thematic relations even if we have a different syntactic structure, as in (41), where the subject Reuben is the goal and the PP object Fred is the source. Jackendoff concluded that one NP can function in more than one thematic role within the same sentence. Thus, the theme

in (40) and (41) is some hashish, Reuben is the source, and Fred is the goal. The specification of such relations can be captured by the fact that with both buy and sell, the subject is the agent, but with buy it is also the goal, whereas with sell it is also the source as in (42) and (43).

(42) Fred bought some hashish from Reuben.
 Agent/Goal Theme Source

(43) Reuben sold some hashish to Fred.
 Agent/Source Theme Goal

The central element which determines the thematic relations in Jackendoff's model is the verb. The lexical entry of the verb will correlate the thematic relations and grammatical relations. The abstract notion of the verb will be operating in two universal predicates: Jackendoff called them CAUSE and CHANGE predicates. The CAUSE predicate takes two arguments: (a) individual and (b) event. The CHANGE predicate takes three arguments: (a) individual, (b) initial, and (c) final state. Thematic relations, then, can be defined within the framework of these predicates. CAUSE takes an Agent as an argument, CHANGE takes a Theme as an individual argument, Source as an initial state argument, and Goal as an argument of final state. Other thematic relations can be defined in the framework of the existential predicate BE which takes a theme as an individual argument and location as a state argument, as in (44).

- (d) Finally, the model can express adequately the reciprocity of the source-goal patterns in verbs such as (buy) and (sell).

5. The Case Grammar Theory of Cook

Case Grammar is a theory whose goal is to describe the semantic content of sentences. Case Grammar went beyond the semantic modifications of EST, because the semantic phenomenon is deeper than the deep structure in these modifications. Note that the developments of the semantic component of Fillmore, Chafe, and Cook are parallel developments to the semantic component of Gruber and Jackendoff. They are not necessarily (and certainly in the case of Chafe and Cook) intended as a development in TGG. However, Case Grammarians believe that Jackendoff's theory can be improved by comparison with other case models.

It would be useful to investigate Case Grammar theory through one advanced and comprehensive version of its semantic development, namely, the matrix model (Cook, 1979).

5.1. The Matrix Model

The matrix model was proposed by Walter A. Cook (1979). It is a system of cases which are assigned by the semantic valence of the verb. One may speak of verb types in terms of features (as is done in Chafe, 1970), with the case roles assigned according to the semantic features of the verb. In this sense, the verb is a semantic governor and controls the number and kind of cases that occur with the verb. In

this system, the list of features which may occur within the verb and describe its valence are to be distinguished from the case roles which are imposed upon the noun because of these features in the verb.

The verb features include, in the vertical dimension of the matrix, state, process, and action. Every verb has one and only one of these features; no verb occurs without one of these features. In general, the [+ stative] feature requires an O_s case role, the [+ process] requires an O' case role, and the [+ action] feature requires both A and O roles. (In Chafe, these were called Action-Process verbs; the feature Action requiring the Agent role and the feature Process requiring the O role, in a one-to-one relationship.)

In the horizontal dimension of the matrix, the feature [+ Experiential] requires the E-role, the feature [+ Benefactive] requires the B-role, and the feature [+ Locative] requires the L-role. The features experiential, benefactive, and locative are mutually exclusive. Basic verbs have none of these. The result of the matrix verb type is 12 case frames, as shown in Figure 2.

Verb Types	Basic Verbs	Experiential	Benefactive	Locative
1. State	O _s BE tall	E, O _s like	B, O _s have	O _s , L be in
2. Process	O die	E, O enjoy	B, O acquire	O, L move, iv
3. Action	A, O kill	A, B, O say	A, B, O give	A, O, L put

FIGURE 2. THE MATRIX VERB TYPES (COOK, 1979:203)

The matrix model distinguishes two kinds of case roles:

- (a) Overt Roles: which occur in the deep structure and always occur in the surface structure.
- (b) Covert Roles: Which occur in the deep structure but may or may not occur in the surface structure. Covert roles are of various kinds. If the role sometimes occurs and sometimes does not occur in the surface structure, then it is called a deletable role, as in (49) and (50).

(49) John is eating. A, O/O-deleted

(50) John is eating (something). A, O

If the role never occurs in the surface structure, it may be either (a) coreferential with another case role, and therefore not manifested separately, as in (51) and (52)

(51) John went home.

(52) John A, = John O.

or it may be (b) lexicalized into the verb as in (53) and (54).

(53) John put water on the garden. A, O, L

(54) John watered the garden. A, *O, L/O-lexicalized

I shall exemplify the matrix model by using the basic structures of the Arabic sentence, as follows:

1. [+ Stative]

This stative feature of the verb, which is indicated in the matrix model by marking the O-case as O_s , expresses the semantic aspect of a derived Arabic sentence such as (55).

(55) ʔal - kaʔsu maksūrun
 the glass broken
 The glass is broken.

2. [+ Process]

The process feature expresses the semantic aspect of the dynamic non-agentive Arabic sentence, as in (56).

(56) yankasiru l - kaʔsu
 breaks the glass
 The glass breaks.

3. [+ Active]

The active feature expresses the semantic aspect of the dynamic agentive Arabic sentence as in (57).

(57) yaksiru zaydun il - kaʔsa
 breaks Zayd the glass
 Zayd is breaking the glass.

4. [+ Experiential]

The experiential feature expresses the semantic aspect of the Arabic sentence whose verb expresses emotion, sensation, or cognition. Experiential verbs can be classified under three types:

4.a. State Experiential Verbs, as in (58).

(58) xawwafa zaydun ^camran
 frightened Zayd ^cAmr
 Zayd frightened ^cAmr.

4.b. Process Experiential Verbs, as in (59).

(59) yaʔmalu zaydun bi-n-najāḥi
 hope Zayd success
 Zayd hopes that he will succeed.

4.c. Action Experiential Verbs, as in (60).

(60) qāla zaydun il-ḥaqīqah
 said Zayd the truth
 Zayd said the truth.

5. [+ Benefactive]

The benefactive feature expresses the semantic aspects of the Arabic sentence whose verb expresses possession, loss or gain, and transfer of objects. Benefactive verbs can be classified under three types:

5.a. State Benefactive Verbs, as in (61).

- (61) li - taʔabbata^vsarran jawādun ʔaṣīlun
 to Taʔabbata^vsarran horse thoroughbred
 Taʔabbata^vsarran has a thoroughbred horse.

5.b. Process Benefactive Verbs, as in (62).

- (62) ḥaṣala zaydun ʕala l-jāʔizati
 acquired Zayd on the present
 Zayd acquired the present.

5.c. Action Benefactive Verbs, as in (63).

- (63) ʔa^cṭaytu zaydan jāʔizatan
 gave I Zayd present
 I gave Zayd a present.

6. [+ Locative]

The locative feature expresses the semantic aspect of the Arabic sentence whose verb expresses stative or directional locations. Locative verbs can be classified under three types:

6.a. State Locative Verbs, as in (64).

- (64) ʕalā raʔsi l - mutanabbi ʕalamun
 on head the Mutanabbi flag
 On the head of ʔAl-Mutanabbi, there is a flag.

6.b. Process Locative Verbs, as in (65).

- (65) taharrakat is-sayyāratu
 moved the car
 The car moved.

6.c. Action Locative Verbs, as in (66).

(66) harraka zaydun is-sayyārata
 moved Zayd the car
 Zayd moved the car.

In addition to these semantic cases of the matrix model, the Arabic structures are based on three universal semantic predicates which describe the deep representation of Arabic sentences. These universal predicates are the following:

(7) BE, (8) COME ABOUT, and (9) CAUSE.

7. BE-Predicate

This predicate expresses the semantic aspect of the nominal existential sentence in Arabic, as in (67) and (68).

(67) ?al - ka?su { maksūrun
 the glass { broken
kabīrun
 large }

The glass is { broken }
 { large } → state (BE+ADJ)

(68) ?al - ka?su { ^cala l-mā?idati
 the glass { on the table
hunā
 here }

The glass is { on the table }
 { here } → Locative state (BE+Loc)

8. COME ABOUT = (CA)

The COME ABOUT predicate expresses the semantic aspect of some intransitives, namely those which are derived from states. This can be seen in (69a) and (69b).

(69) a. yankasiru l - ka?su
 break the glass
 The glass breaks.

b. COME ABOUT (BE KSR (ka?s))

9. CAUSE

The CAUSE predicate expresses the semantic aspect of some dynamic agentive transitive structures of the verbal sentence, as in (70a) and (70b).

(70) a. yaksiru zaydun il - ka?sa
 break Zayd the glass
 Zayd is breaking the glass.

b. CAUSE (Zayd, CA (BE KSR (ka?s))

5.2. The Bidirectional System

The Arabic analysis will be based on the bidirectional system of derivation which was proposed by Chafe (1970) and adopted by Cook (1979). There are two reasons for using such a system in the Arabic analysis:

- (a) The bidirectional system is applicable within the framework of the matrix model of the case system on which the Arabic framework is based.

- (b) This system is also applicable to the basic sentence and its morphological derivations in Arabic. The morphological process in Arabic depends on what the Arab grammarians called ?iṣṭiqāq, i.e., derivation.

Syntactically, however, the Arabic data require such a bidirectional system to meet the three base-generated structures of the sentence, namely: the nominal transitive and intransitive complex sentence, the nominal equational sentence, and the verbal transitive and intransitive sentence. The bidirectional system can be applied to these sentences adequately.

The bidirectional system of derivation consists of four semantic units:

1. Inchoative Derivation (ID)
 - a. [ID + State] \longrightarrow [+ Process]
 - b. COME ABOUT, (BE X (Z))
2. Resultative Derivation (RD)
 - a. [RD + Process] \longrightarrow [+ State]
 - b. BE X (Z)
3. CAUSATIVE Derivation (CD)
 - a. [CD + Process] \longrightarrow [+ Action]
 - b. CAUSE (Y, COME ABOUT (BE X (Z)))
4. Decausative Derivation (DD)
 - a. [DD + Action] \longrightarrow [+ Process]
 - b. COME ABOUT (BE X (Z))

According to Chafe (1970), some verbs are inherently state, action, process, action/process, and others only

derivatively so. The semantic derivational process of the bidirectional system can be seen in Figure 3.

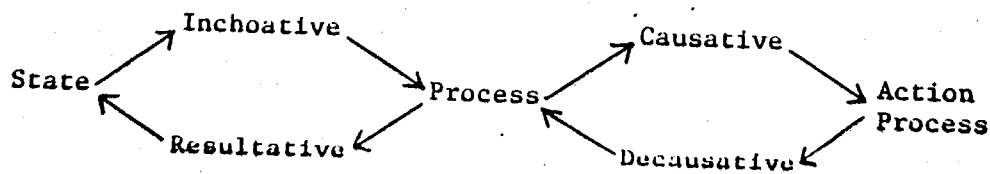

FIGURE 3. THE BIDIRECTIONAL SYSTEM (Chafe, 1970:132)

Applying this system to the basic sentence and its derivation in Arabic, we can have the following semantic structures:

(71) a. ʔal-kaʔsu maksūrun
 the glass broken
 The glass is broken.

b. BE MA+ KSR (kaʔs) By ID →

(72) a. ʔinkasara l-kaʔsu
 broke the glass
 The glass broke.

b. COME ABOUT (BE ʔint+ KSE (kaʔs)) By CD →

(73) a. kasara zaydun il-kaʔsa
 broke Zayd the glass
 Zayd broke the glass.

b. CAUSE (Zayd, COME ABOUT (BE KSR (kaʔs)))

(74) a. fataḥa zaydun il-bāba
 opened Zayd the door
 Zayd opened the door.

b. CAUSE (Zayd, CA(BE FTH (bāb))) By ID →

(75) a. ʔinfataḥa l-bābu
 opened the door
 The door opened.

b. COME ABOUT (BE ʔin+ FTH (bā) By DD →

(76) a. ʔal-bābu maftūḥun
 the door open
 The door is open.

b. BE MA+ FTH (bāb)

5.3. The Comparison between Case Theory and Thematic Theory

Jackendoff (1972) rejected the Case Grammar Theory proposed by Fillmore (1968). The main reason for such rejection was that the Case Grammar of Fillmore lacks coreference. Instead, Jackendoff adopted the Thematic Theory of Gruber (1965). Recently, most linguists consider the Thematic model to be subsumed under the theory of Case Grammar, since Fillmore (1970) added the notion of coreference. The argument here can be drawn from the following facts:

1. Case Grammar is not a grammar and does not deal directly with surface case. It is simply a descriptive semantic system which "deals only with the semantic level in a grammar" (Cook, 1982:1).

Jackendoff (1972) used the thematic relations (a case grammar role system) of Gruber (1965) in the interpretive level of a transformational generative grammar.

2. The case lists in Gruber's and Jackendoff's models are localistic. That means the case list uses source and goal cases along with location. These three cases are also used in the abstract sense. The case grammar-matrix model is non-localistic, i.e., the case list does not use source or goal cases, but it groups stative and directional locatives under one case, namely physical location. The case list in the matrix model has other cases such as Agent, Experiencer, Benefactive, and object (theme).
3. It follows that any localistic model can be translated into a non-localistic one. Thus, the case list in thematic relations of Jackendoff and Gruber can be translated into the case list into Cook's matrix model, and vice versa.
4. Jackendoff (1972:29) openly adopts the thematic theory of Gruber (1965) without any substantial change or modification.
5. The thematic theory applied by Jackendoff has some weak points which can be explained as follows:
 - (a) Since basic verbs require only Theme, or Agent and Theme, there is no justification in the case frame used by Jackendoff. In his thematic relations, every case frame seems to have source and goal, as in this example: "The door opened." Theme: door, Source: not open, Goal: open. The model might be better served if basic verb types occurred without Location, Source, or Goal cases, as in Anderson (1971).

- (b) In Gruber's thematic model, Agent is introduced only in the latter part of his work, and gives the impression that Agent only occurs in verbs from which the notion of CAUSE can be factored. This presents a difficulty in the analysis of simple action verbs like laugh, work, dance, sing, which are obviously agentive.

We can conclude that, with minor modifications, the Thematic model would serve the matrix model, or the matrix model could be used for semantic interpretation in Transformational Generative Grammar. It follows, then, that the incorporation of the matrix model as a descriptive semantic interpretation in transformational grammar which can be readjusted according to the sentential Arabic theory would offer the brightest prospects for a modern sentential theory of the Arabic structures.

CHAPTER THREE

BASIC STRUCTURES

0. Introduction

In this chapter, I shall analyze and explain the basic structures in standard Arabic. By basic structures is meant those structures which are subsumed under (a) verbal structure (M-MI-F), and (b) nominal structure (MI-M-F).

The purpose of this analysis is to investigate the surface and deep representations of these structures and capture the freer and more restricted movement of their constituents. In order to do so, insights from Arabic sentential theory, Cook's matrix model, and transformational generative grammar theory have been adopted.

1. Theoretical Framework

Theoretical frameworks of the basic sentence in Arabic vary from one linguist to another, depending on the theory which each linguist adopts. Thus one who tries to investigate the theoretical framework of the Arabic sentence will face different proposals concerning the configurational structure and its rules that capture the syntax and semantics of the Arabic sentence. The configurational structure and the rules that account for the Arabic sentence come from two sources: the first was proposed by Western linguists who conceived of the structural framework

of the Arabic sentence from their modern linguistic background. The second was proposed by Arab linguists who understood the structure of the Arabic sentence through a particular modern linguistic approach. The problem in both sources of analysis is that they approached syntactically, but less so semantically, the immediate and more applicable data which conform to the theoretical principles of the theory they adapted. The result of such analysis is insufficient and inadequate semantic explanation.

Snow (1965), Killean (1966), Lewkowicz (1967), and Awwad (1973), for example, believed the structure of the Arabic basic sentence to consist of the following rule:

$$(1) \quad S \longrightarrow \left\{ \begin{array}{l} NP + VP \\ NP + Pred \end{array} \right\}$$

Other linguists, however, conceived of the Arabic basic sentence differently. Anshen and Schreiber (1968) understood the structure of the basic sentence to consist of the following rule:

$$(2) \quad S \longrightarrow VP + NP$$

Aoun (1979) suggests that we can understand the basic sentence in Arabic, or more generally in VSO languages, as having flat structure, which he gives as follows:

$$(3) \quad S \longrightarrow \text{INFL} - V - \text{SUBJ} - \text{OBJ}$$

More recently, some Arab linguists have deviated from these formulations. Bakir (1980), for example, tried to apply Jackendoff's \bar{x} -theory to the basic sentence in Arabic. The application of \bar{x} -theory resulted in the following rule:

$$(4) \quad v' \longrightarrow v - N''' - (N''') - (P''')$$

The most recent theoretical framework of the Arabic sentence was proposed by Fihre (1981). Fihre adopts a theoretical framework called "A Lexical Functional Grammar," proposed by Bresnan (1976-1982). Fihre tried to apply the constituent structure (C-structure) of this theoretical framework to the basic sentence in Arabic. His understanding of the basic structure is similar to that of Bakir's (1980), except that Bakir's framework was Jackendoff's \bar{x} -theory. The "Lexical Functional Grammar" framework resulted in the following rule:

$$(5) \quad s \longrightarrow v - \begin{array}{c} NP \\ \uparrow \downarrow \end{array} - \begin{array}{c} NP \\ \uparrow \downarrow \end{array}$$

(↑SUBJ)=↓ (↑OBJ)=↓

In fact, these theoretical frameworks can account for some Arabic data (such as verb phrase and noun phrase), but they cannot capture other data (such as active and passive participles). I shall present here the basic syntactic and semantic assumptions of the underlying structure of the Arabic sentence, using the Arabic framework. In addition, I shall raise the possibility of fusing and converting such a framework in the case grammar of the matrix model

proposed by Cook (1979) and in the general notion of the basic transformational grammar proposed by Chomsky (1970-1981) in order to capture the structure of the Arabic sentence, syntactically and semantically.

Recall the structure of the Arabic sentence consists of three constituents. The first essential constituent is called musnad (M), i.e., M-predicate of the sentence. The second essential constituent is called musnad ?ilayhi (MI), i.e., MI-subject or topic. The third constituent is called Faḍlah (F), i.e., adjunct or all constituents which are neither M nor MI. F enters the structure as an extra constituent which contributes to the meaning of the sentence and deepens it. The relation which holds among these structural constituents is called ?isnād (IS), i.e., configurational predication. The IS-node is dominated by the highest K-node or sentence. I shall introduce here another constituent which can transform the basic structure to a new structure. The new constituent is called ?adāt (AD), i.e., particle. The constituent AD can be different syntactic categories, such as Q-word, Neg-word, Comp-word, and Conditional-word. I shall describe the underlying structure of the Arabic sentence by using the five case roles proposed in the matrix model, i.e., (a) Agent = A, (b) Experiencer = E, (c) Benefactive = B, (d) Locative = L, and (e) Object = O. In addition, I shall describe the underlying structure of the Arabic sentence by using the

three case markers, i.e., (a) Nominative - Nom,
 (b) Accusative = Acc, and (c) Genitive = Gen.

Applying this theoretical framework to the basic sentence in Arabic, we can understand the structure of the Arabic sentence, as in (6) and (7).

- (6) a. ḍaraba l-mūsayāni l-^cīsayayni
 hit the two Moseses the two ^cīsās
 The two Moseses hit the two ^cīsās.

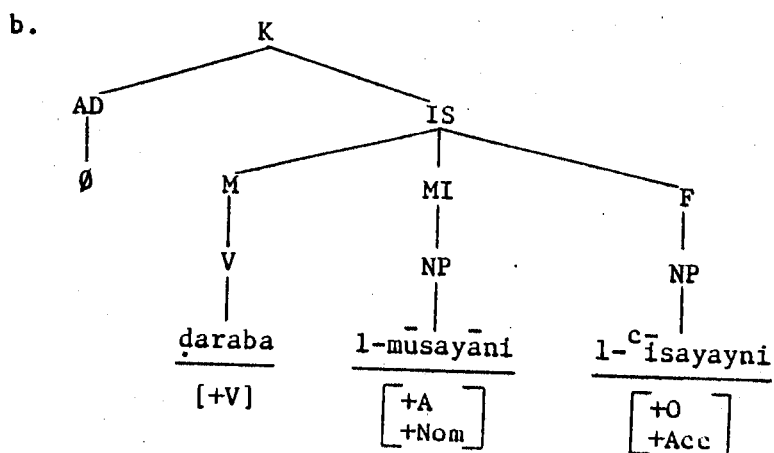

- (7) a. ?a dāribun mūsā ^cīsā ?
 Q hitter Moses ^cīsā
 Is Moses the hitter of ^cīsā?

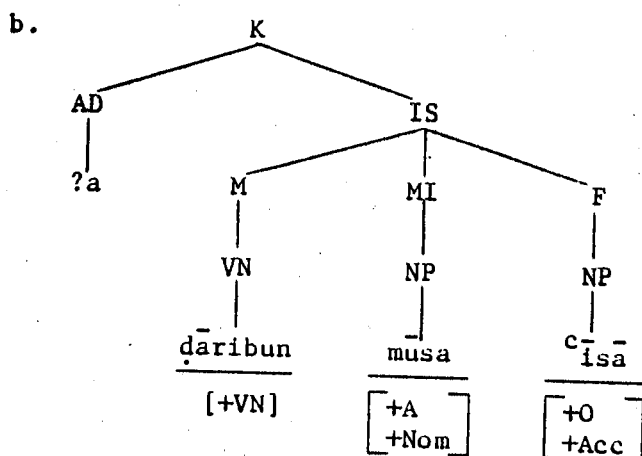

As seen in the configurations above, the predicate M(V) in (6b) is a verb, but it is a verbal noun M(VN) which is derived from the verb in (7b). This means that the VN can function exactly as if it were a verb, i.e., it can occur in the position of the verb and inherit its syntactic and semantic features. It requires, as in (7b), an MI(NP-agent) and an F(NP-object).

In fact, there is a large body of Arabic morphology which can express different functions depending on the constituents inherited from the verb. Arabic structures show three categories which function as if they were verbs. The first is called ?ismu l-fā^cil, i.e., active participle verbal noun (AVN) which occurs in the active sentence. The second is called ?ismu l-maf^cūl, i.e., the passive participle verbal noun (PVN) which occurs in the passive sentence. The third is called ?aṣ-ṣifatu l-muṣabbahatu bi-?ismi l-fā^cil, i.e., the verbal adjective which is similar to the verbal noun (AdjVN) which occurs in an adjective position to modify a preposed noun to its left. These categories can collapse under one category, i.e., the VN category.

The binary set of the lexical category in Arabic can be shown as in (8).

(8) a.

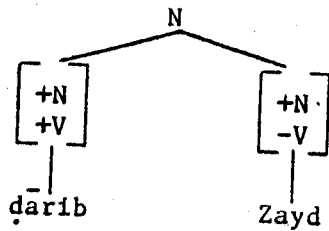

b.

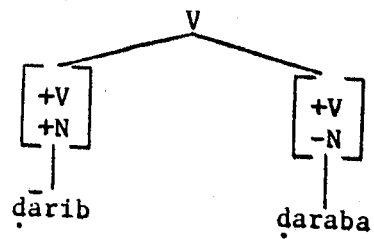

c.

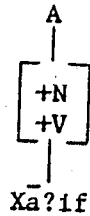

d.

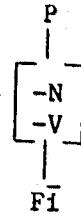

Formalizing rules based on these categories, I shall propose that the rules which can account for the Arabic data would be of the following nature:

(9) $K \longrightarrow AD-IS$ (10) $IS \longrightarrow \left\{ \begin{array}{l} M-MI-F \\ MI-M-F \end{array} \right\}$ (11) $AD \longrightarrow \left\{ \begin{array}{l} \pm O \\ Neg \\ \dots \end{array} \right\}$ (12) $M \longrightarrow \left\{ \begin{array}{l} S \\ V \\ VN \\ NP \\ AP \\ PP \\ AdvP \end{array} \right\}$ (13) $MI \longrightarrow \left\{ \begin{array}{l} S \\ VN \\ NP \end{array} \right\}$

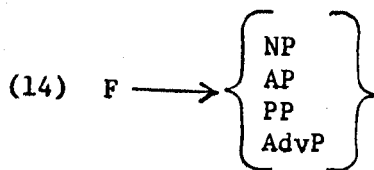

All particles (AD) which might modify the sentence do not affect the essential structure of the IS-node. I shall consider the notion of particle (AD) to be beyond the domination of the essential structure of the sentence, i.e., the essential constituents are not dominated by the same node which dominates particle (AD). This can be seen in (15).

- (15) a. hal yugadiru zaydun gadan ?
 Q leave Zayd tomorrow
 Does Zayd leave tomorrow?

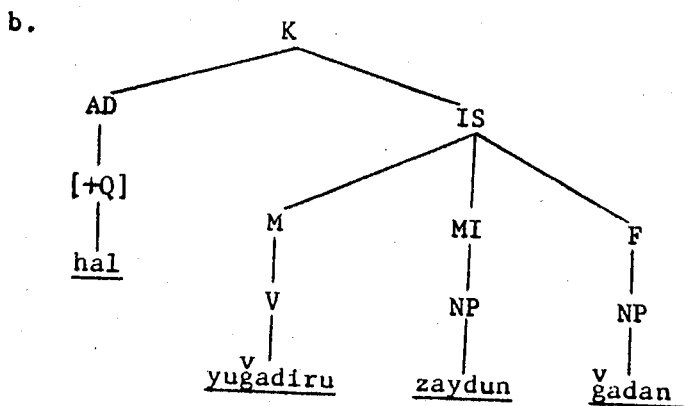

Let us consider some examples which clarify this theoretical issue.

- (16) a. ?a zaydun ?axū -ka ?
 Q Zayd brother your
 Is Zayd your brother?

b. $\overbrace{\text{mā}}^{\text{AD}}$ $\overbrace{\text{zaydun } \text{ṣā}^{\text{C}} \text{iran}}^{\text{IS}}$
 Neg Zayd poet
 Zayd is not a poet.

c. $\overbrace{?a}$ $\overbrace{\text{musāfirāni } 1 - \text{ḥisayāni}}^{\text{IS}}$?
 Q traveler ?al-ḥisayāni
 Are ?Al-ḥisayāni travelers?

(17) a. $\overbrace{?a}$ $\overbrace{\text{tugannī } \text{mayyun}}^{\text{IS}}$?
 Q sing Mayy
 Is Mayy singing?

b. $\overbrace{\text{mā}}$ $\overbrace{\text{qāla } \text{ṣ-ṣi}^{\text{C}} \text{ra } \text{zaydun}}^{\text{IS}}$
 Neg say poetry Zayd
 Zayd never said poetry.

c. $\overbrace{\text{hallā}}$ $\overbrace{?ansadtani }^{\text{IS}}$ $\overbrace{\text{ṣi}^{\text{C}} \text{ran}}$ $\overbrace{\text{yā}}$ $\overbrace{\text{ḡulām}}$?
 Q-like recite me poetry o boy
 O boy, would you recite me poetry?

We notice from the above examples that the nominal structures (IS) in (16) and the verbal structures (IS) in (17) consist of particles (AD) which are sister-adjoined to the node (IS), but never to the constituents that are dominated by (IS), because the essential constituents hold only among M, MI, and F which are sister-adjoined and

dominated by the node (IS). The node (AD), however, is an extra syntactic category which is sister-adjoined to the node (IS). The nodes (AD) and (IS) are dominated by a higher node which organizes the whole configurational process of the complete structure, i.e., K-node.

The configurational structures of the sentences (18a) and (19a) can be shown in (18b) and (19b).

- (18) a. ?a ?abū-nuwāsa ṣa^{-c}irun ?
 Q ?Abu-nuwāsa poet
 Is ?Abū-nuwāsa a poet?

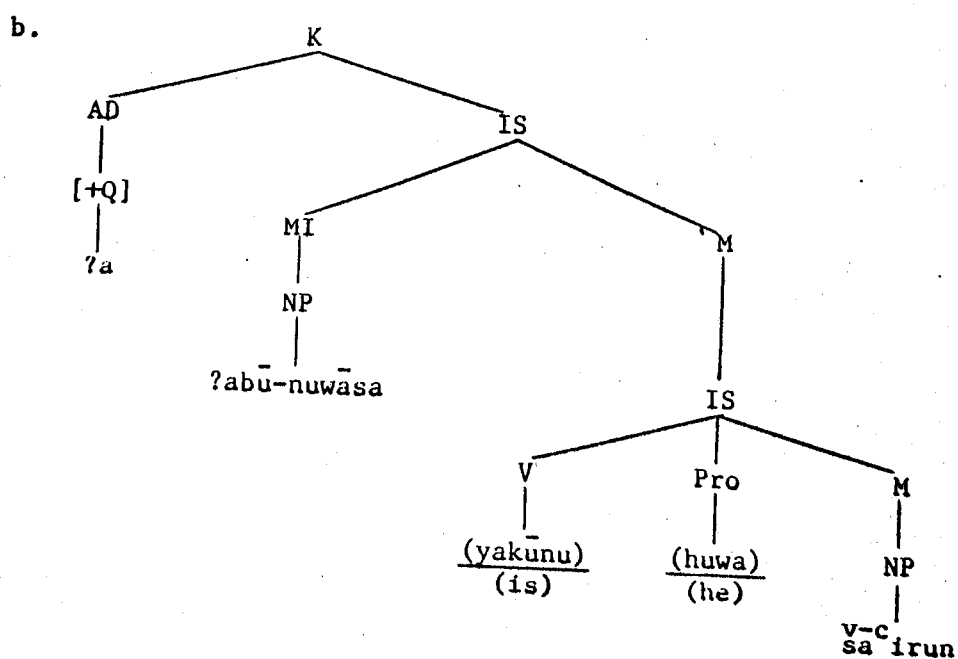

- (19) a. ?a haraba l-mutanabbī ṣ - ṣuǰā^{-c}u ?
 Q escaped ?Al-Mutanabbi the courageous
 Did the courageous Mutanabbi escape?

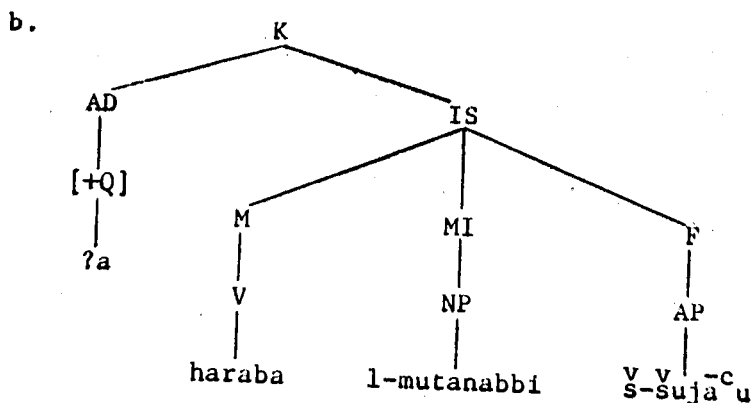

The clarification of the new framework adopted here can be seen from the following verbal and nominal structures, presented in (20) and (21).

- (20) a. ?a hajā ta?abbatasa^Vsarran jārallāhi ?
 Q satirized ta?abbatasa^Vsarran Jārallāhi
 Did Ta?abbatasa^Vsarran satirize Jārallāhi?

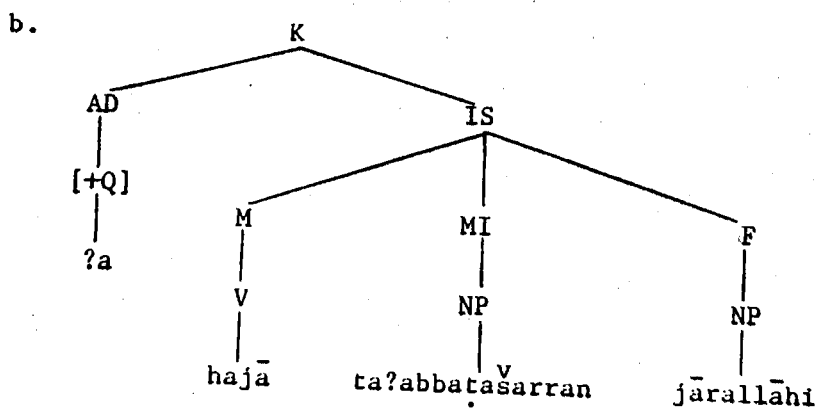

- (21) a. ?ā l-xansā?u ?axū - hā ṣaxrun ?
 Q ?Al-Xansā?u brother her Ṣaxr
 As for ?Al-Xansā?, is Ṣaxr her brother?

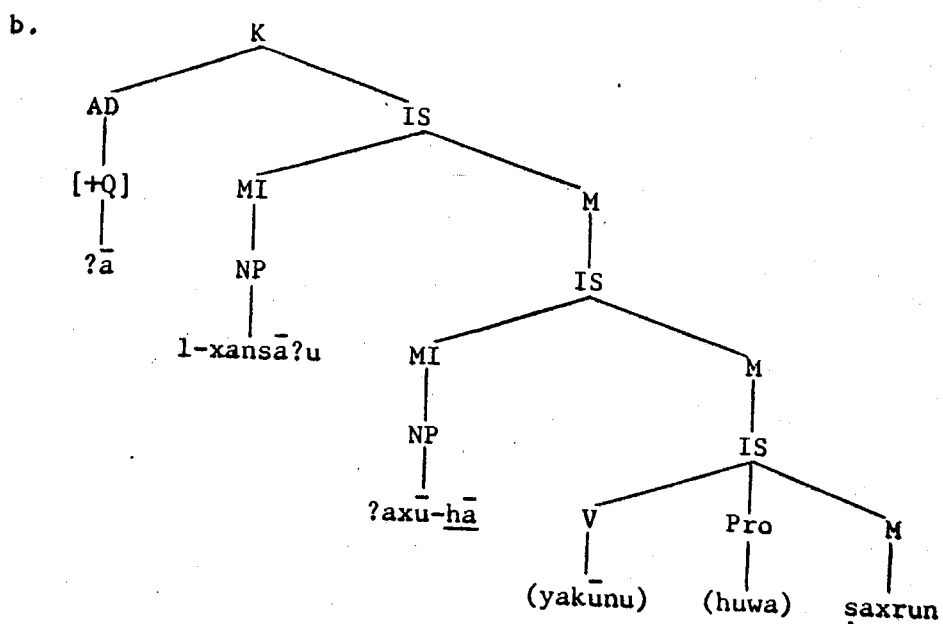

2. Word Order in Basic Structures

In this section, I will focus on the basic order of the Arabic sentence and its possible derived structures. After that, I will explain the structural and functional aspects of such moving elements.

2.1. Word Order in Verbal Structures

The word order of the basic verbal sentence in Arabic might be in (22).

(22) [M(V)...MI(NP)...(F₁(NP)...(F₂(X)))]

The constituents in (22) can be seen, for example, in sentence (23).

(23) $\begin{array}{c} \text{M} \quad \text{MI} \quad \text{F}_1 \quad \text{F}_X \\ \boxed{\text{daraba}} \quad \boxed{\text{zaydun}} \quad \boxed{\text{?axā} - \text{hu}} \quad \boxed{\text{darban} \quad \text{V} \text{sadīdan}} \\ \text{hit} \quad \text{Zayd} \quad \text{brother his} \quad \text{hitting strongly} \end{array}$

$\begin{array}{c} \text{F}_X \quad \text{F}_X \quad \text{F}_X \\ \boxed{\text{yawma} \quad \text{l-jum}^{\text{C}} \text{ati}} \quad \boxed{\text{?amāma} \quad \text{rifaqi} - \text{hi}} \quad \boxed{\text{ta?dīban} \quad \text{la- hu}} \\ \text{day} \quad \text{Friday} \quad \text{in front} \quad \text{friends his} \quad \text{punishing} \quad \text{to him} \end{array}$

Zayd hit his brother a very strong hit on Friday in front of his friends as a punishment for him.

The constituents (M-MI-F₁) in (23) represent the basic elements; all other constituents can be collapsed under the category F(X). The structure in (23) allows certain elements to move to the left or to the right of the verb, transformationally. Let us consider the following examples.

(24) a. $\begin{array}{c} \text{daraba} \quad \text{zaydun} \quad \text{?axā} - \text{hu} \\ \text{hit} \quad \text{Zayd} \quad \text{brother his} \\ \text{Zayd hit his brother.} \end{array}$

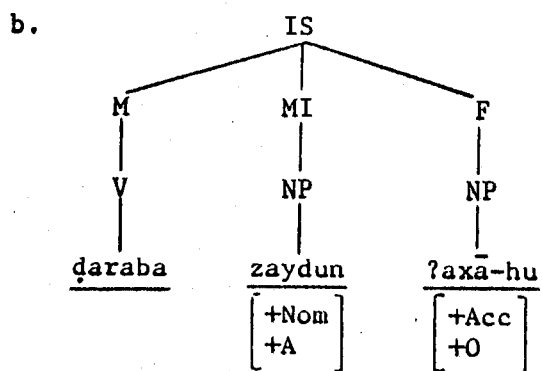

(25) a. $\begin{array}{c} \text{daraba} \quad \text{?axā} - \text{hu} \quad \text{zaydun} \\ \text{hit} \quad \text{brother his} \quad \text{Zayd} \end{array}$

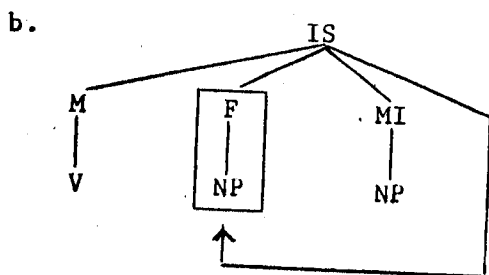

(26) a. ʔaxā - hu ḍaraba zaydun
 brother his hit Zayd

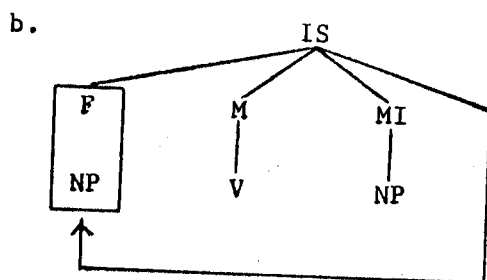

The movement in such structures can be seen as in (25b), where the F(NP-object) is preposed to the right of the verb, and as in (26b), where the F(NP-object) is preposed to the left of the verb.

The structure in (24) and its transformations, as in (25) and (26), will account for the transformational F(NP-object). Thus, any transformational movement to the right or to the left of the verb is permissible only within the domain of the IS-node. The justification for such movement is that the constituents are assigned case roles and case markers, and then when the constituents move, they will move with these syntactic and semantic case roles and case markers.

The movement, however, is permissible in the case of F(NP-object), but not in the case of MI(NP-subject or agent). The non-permissible extraction of the MI(NP-agent) comes from the fact that the M(V) and MI(NP-subject) are one linguistic unit, which cannot separate and move in the structure. All other constituents can move within the structure. In the case of (25) and (26), the F(NP-object) is an adjunct which can move freely. The process of movement within the structural domain can be seen in (27), where the movement of the F(NP-object) must be to a sister-adjoined position within the domain of the IS-node but not the K-node.

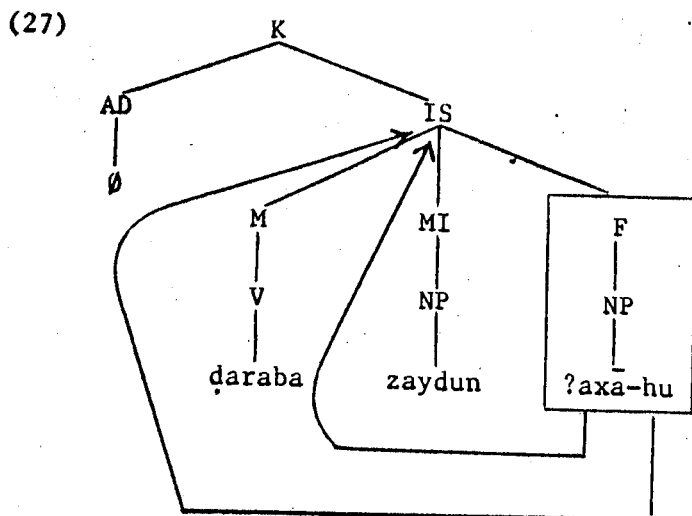

The F(NP-object) in (27) can move to either the left or right of the verb within the domination of the IS-node.

We have discussed so far the movement of the F(NP-object) in the verbal structure. The movement rule, however, can apply to any constituent which can appear under the category F(X). Let us consider the following examples.

- (28) a. jā?a rajulun min al-madīnati
 came man from the city
 A man came from the city.

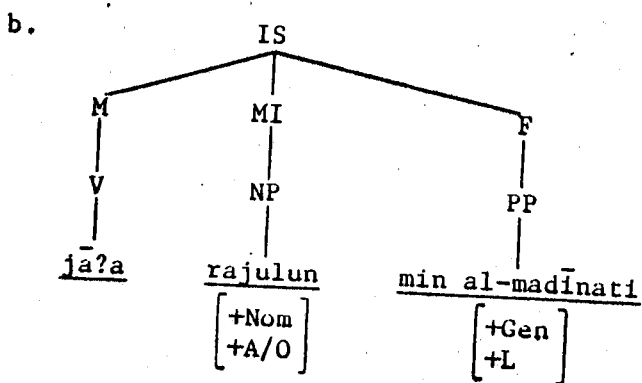

- (29) a. jā?a min al-madīnati rajulun
 came from the city man

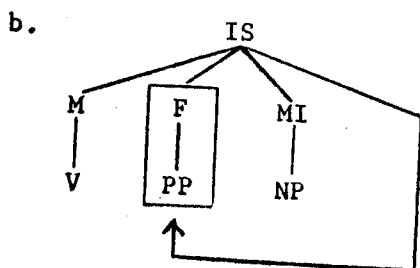

- (30) a. min al-madīnati jā?a rajulun
 from the city came man

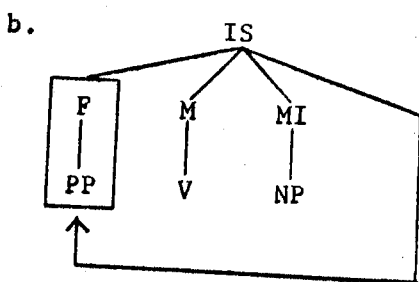

As seen in (29b) and (30b), the category F(PP) can move either to the left of the M(V) or to the right of it. Once

again, the constraint in such movement is that it must be within the domain of the IS-node.

2.1.1. Constraints on Word Order in Verbal Structures

In certain syntactic and semantic cases, the constituents within the verbal structure cannot move freely from one position to another, for reasons which have to do with syntactic and semantic ambiguities. The movement in the ambiguous structures will cause ungrammaticality. Let us consider the following examples.

(31) a. $\frac{\text{ḍaraba}}{\text{hit}}$ $\frac{\text{mūsā}}{\text{Moses}}$ $\frac{\text{c-īsa}}{\text{c-īsa}}$
 Moses hit c-īsa.

b. $\frac{\text{ḍaraba}}{\text{hit}}$ $\frac{\text{hāoā}}{\text{this}}$ $\frac{\text{hāoā}}{\text{this}}$
 This (man) hit this (man).

c. $\frac{\text{ḍarabat}}{\text{hit}}$ $\frac{\text{il - ḥubla}}{\text{the pregnant}}$ $\frac{\text{s - sakra}}{\text{the drunk}}$
 The pregnant (woman) hit the drunk (woman).

The above examples do not tell us who is the doer of the action, and who was acted upon because it is not clear whether the first constituent to the right of the verb has the case role of agent and case marker of nominative, or the case role of object and the case marker of accusative. But since the case markers are not shown on the words, movement of the constituents is not allowed lest there be

ambiguity. The movement has to have some constraints which can capture this ambiguity and clarify it. There are some constraints which concern such structures. These constraints can be stated as follows:

- (32) a. In structures such as in (31), the first constituent must be an agent which has a nominative case marker. The second constituent must be an object which has an accusative case marker.
- b. Movement cannot be applied in such structures unless (a) holds, i.e., we cannot move any constituent to prepose or postpose the verb.

The constraints (32a) and (32b) can be relaxed only if the structure has a syntactic or semantic clue which indicates the subject and the object, and thus it will allow constituents to move freely. This means that sentences which have no semantic or syntactic clue which enables the constituents to move have a strict and fixed word order.

Applying the constraints above to the structure in (31), we can conclude that the constituent which is found on the right of the verb must be the MI(NP-subject), even though it is not marked nominative, and the constituent which is to the right of the MI(NP-subject) must be F(NP-object), even though it is not marked accusative.

When structure, however, has a certain syntactic or semantic clue, the movement rule can apply freely without any restrictions. These syntactic and semantic clues can be seen in the following examples.

(33) a. ḍaraba mūsā l - qawīyyu ḥīsā
 hit Moses the strong ḥīsā
 The strong Moses hit ḥīsā.

a'. ḍaraba ḥīsā mūsā l-qawīyyu

b. ḍaraba-t hāōi-hi hāōā
 hit this(f) this(M)
 This (woman) hit this (man).

b'. ḍaraba-t hāōā hāōi-hi

c. ḍaraba l - mūsayūna l - ḥīsayīna
 hit the Moseses the ḥīsās
 The Moseses hit the ḥīsās.

c'. ḍaraba l-ḥīsayīna l-mūsayūna

(34) a. ?akalat il - ḥublā l - ḥalwā
 ate the pregnant the candy
 The pregnant woman ate the candy.

a'. ?akalat il-ḥalwā l-ḥublā

b. ?akala ḥīsā l-kummaθrā
 ate ḥīsā the pears
 ḥīsā ate the pears.

b'. ?akala l-kummaθrā ḥīsā

c. ?asarrat laylā n - najwā
 kept Laylā the secret
 Laylā kept the secret.

c'. ?asarrat in-najwā laylā

In the above examples of (33) and (34), constituents can move freely, since there are syntactic and semantic clues which indicate who is the MI(NP-subject) and the F(NP-object). In the examples in (33), the clue is syntactic. In (33a), the MI(NP-subject) is modified by an adjective whose case marker is a nominative; thus the MI(NP-subject) must have a nominative case marker and consequently would be an MI(NP-subject). In (33b), the clue is the gender. The Arabic verb must agree with the subject which is postposed to the right of it with gender, number, and person, thus the constituent which agrees with the verb in gender must be the MI(NP-subject). In (33c), the clue is that the constituents are marked morphologically with the subject and object as dual markers, thus one can tell the subject from the object.

The semantic clues in the structures of (34) vary. In (34a) and (34b), the semantic clue depends on the lexical verb whose semantic features must be universal, i.e., the person who is the eater must be MI(NP-agent), and the thing which is being eaten must be F(NP-object). We can see that the same semantic relations hold for (34c), because the secret must be kept by a human being who is MI(NP-experiencer), and the talk or secret which is being kept must be F(NP-object). The structures which can capture these syntactic and semantic processes can be seen in (35).

(35) a.

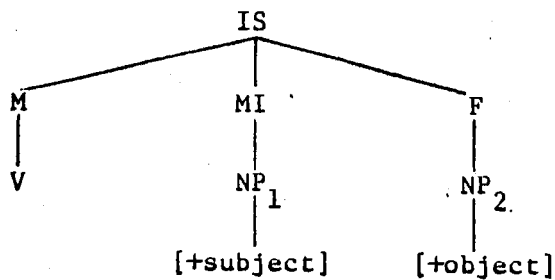

b.

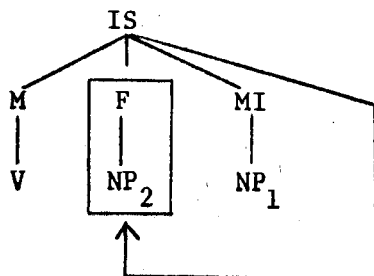

c.

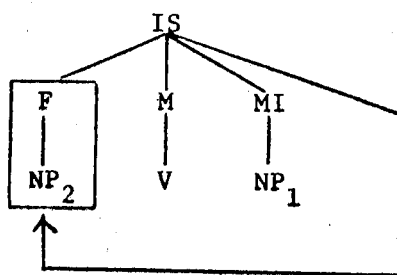

The constraints on the word order can be applied on different kinds of structures. In some structures, we find some verbs which occur with three constituents. The first is MI(NP-subject), and the second and third are existential sentences. The constraint in such structures would be on the order of the two constituents of the existential sentence. It is supposed that the constituent one, which is the theme and which is talked about, must precede the constituent two. In other words, the constituent one which causes the other constituent must come first in the structure from a semantic point of view. The violation of such

constraints will result in ill-formed structures, which might be acceptable. But to achieve a high degree of grammaticality in Chomsky's (1957) sense, one has to apply the previous constraint. This semantic constraint can be seen in (36).

- (36) a. ḥasib - tu v̄ s̄ - v̄ samsa ṭālī^catan
 thought I the sun rising
 I thought that the sun was rising.

In (36a), the structures include two constituents in the existential sentence which express the logical event; thus the sun is the object of which rising is predicated. The logical sequence is that the sun must precede the rising. The structures have a fixed and strict word order which can be shown in (36b).

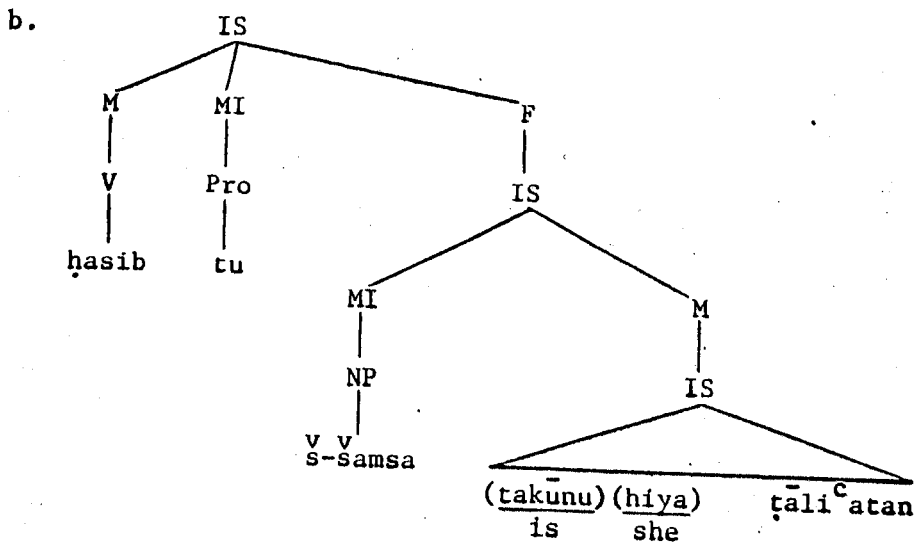

The semantic constraint can be exhibited more clearly in another example where a movement rule is involved. In

some structures, any movement can change the entire meaning of the sentence. This means that a transformational rule would change the semantic structure of the sentence if it moved a certain constituent from one position to another. These semantic changes can be exhibited in the following examples.

- (37) a. marar - tu bi-zaydin rākiban
 passed I by Zayd riding
 I passed by Zayd while he was riding.

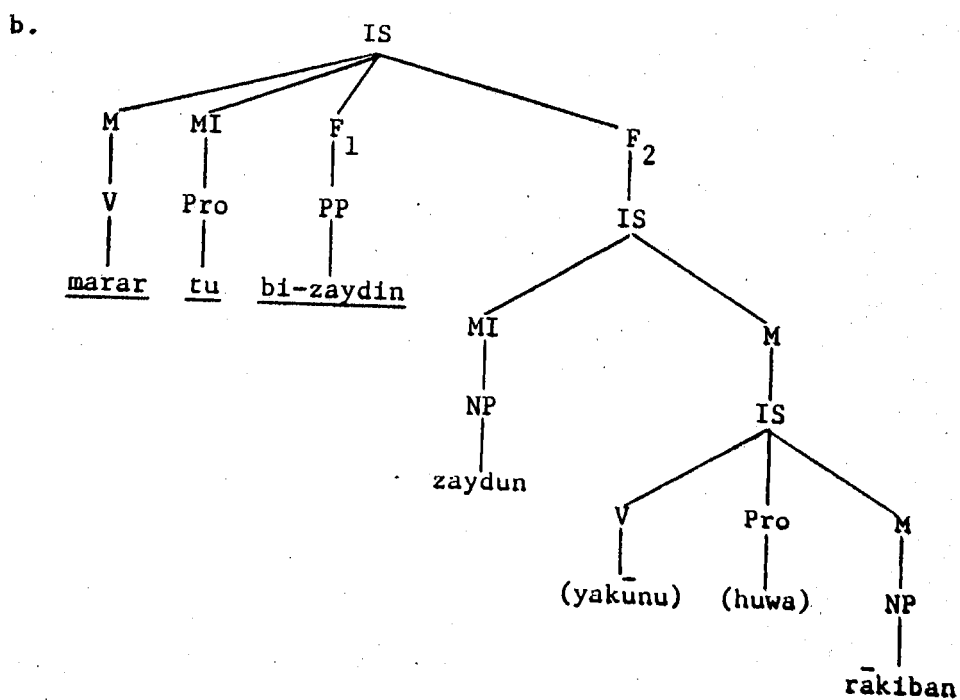

- (38) a. marar - tu rākiban bi-zaydin
 passed I riding by Zayd
 While I was riding, I passed by Zayd.

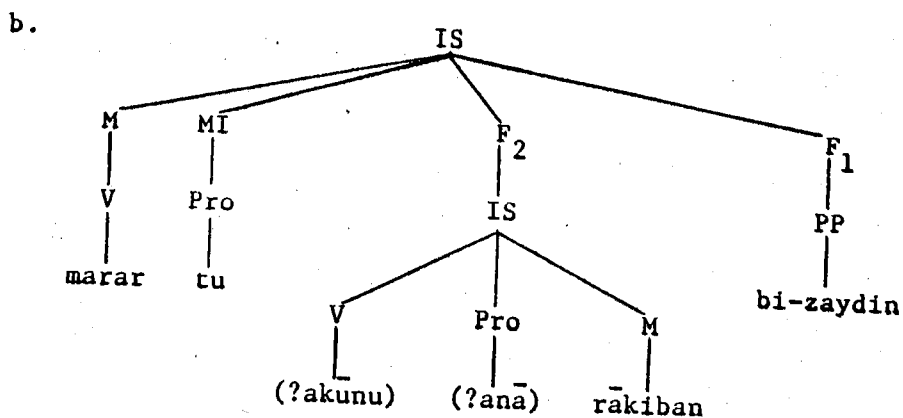

In (37b), the F_2 (sentence) must refer to PP and modify it, but in (38b), it must refer to the MI(Pro-agent) and modify it. Therefore, movement of this kind must be constrained, to avoid semantic ambiguity.

The constraints on movement rule can be exhibited in the complex and conditional clauses of the Arabic sentence, which consists of subordinate and main clauses. The constraint in such structures is that the F in the subordinate clause cannot move to the left of its verb, otherwise it will result in an ungrammatical sentence. See (39b), whose original structure is in (39a), where F is F(AdvP).

- (39) a. man ya^cmal ṣāliḥan fa - linafsi - hi
 who does right then for self his
 One who acts righteously, it would be for himself.

- b.* ṣāliḥan man ya^cmal fa - linafsi - hi
 right who does then for self his

Similar to the conditional structure is the complex structure, where the F(NP-object) cannot move because of the constraint on movement rule in the dependent clause. This restriction can be seen in (40).

(40) a. ʔarāda zaydun ʔan yadriba ^camran
 wanted Zayd to hit ^cAmr
 Zayd wanted to hit ^cAmr.

b.* ʔarāda zaydun ʔan ^camran yadriba
 wanted Zayd to ^cAmr hit

The blockage of the F(NP-object) from moving to the left of the verb is the complementizer ʔan. The complementizer ʔan cannot allow any constituent to intervene between it and its verb. The constraint on movement rule within the complex structure can be applied to the complex sentence. In this structure, the F(NP-object) cannot move to the left of its verbal noun. The restriction on such movement is exemplified in the following examples.

(41) a. sāʔa - nī ḍarbu zaydin ^camran
 bothered me hitting Zayd ^cAmr
 Zayd's hitting of ^cAmr bothered me.

b.* sāʔa - nī ^camran ḍarbu zaydin
 bothered me ^cAmr hitting Zayd

In some structures of the Arabic language, the F(NP-object) is obligatorily moved to the right of the verb. This structural process, however, results in a word order

different from (M-MI-F). Thus the word order of (M-MI-F) in certain structures will violate the grammaticality of the sentence. Instead, the word order must be (M-F-MI). This can be seen in the following examples.

- (42) a. $\overbrace{?intaqada}^M - hu}^F$ $\overbrace{1 - wazīru}^F$ $\overbrace{1 - la?īmu}^{MI}$
 criticized him the minister the sordid
 The sordid minister criticized him.

b.* $\overbrace{?intaqada}^M$ $\overbrace{1 - wazīru}^F$ $\overbrace{1 - la?īmu}^{MI}$ hu

- (43) a. $\overbrace{?a^c jaba}^M - ni}^F$ $\overbrace{?an}^F$ $\overbrace{ḍaraba}^F$ \overbrace{zaydan}^F $\overbrace{?axū - hu}^{MI}$
 surprised me that hit Zayd brother his
 It surprised me that Zayd's brother hit him (Zayd).

b.* $\overbrace{?a^c jaba}^M$ $\overbrace{?an}^F$ $\overbrace{ḍaraba}^F$ $\overbrace{?axū - hu}^{MI}$ \overbrace{zaydan}^F ni

- (44) a. mā $\overbrace{ḍaraba}^M$ \overbrace{zaydan}^F $\overbrace{?illa}^F$ $\overbrace{^c amrun}^{MI}$
 Neg hit Zayd except ^cAmr
 Nobody hit Zayd except ^cAmr.

(Other people besides ^cAmr did not hit Zayd.)

b.* mā $\overbrace{ḍaraba}^M$ $\overbrace{^c amrun}^F$ $\overbrace{?illa}^F$ \overbrace{zaydan}^F

- (45) a. wa $\overbrace{?iōā}^M$ $\overbrace{btalā}^F$ $\overbrace{?ibrāhīma}^F$ $\overbrace{rabbu-hu}^{MI}$ bi-kalimāt
 and then tested Abraham god his by words
 And then God tested Abraham by words. (Holy Qur?ān)

b.* wa ?iōā btalā rabbu-hu ?ibyāhīma bi-kalimāt

(46) a.

	M	F	MI		
(46) a.	?a ^c jaba	zaydan	mā	kariha	?amrun ^c
	pleased	Zayd	what	disliked	?Amr ^c
	What ?Amr ^c disliked pleased Zayd.				

b.* ?a^cjaba mā kariha ?amrun^c zaydan

In examples (42) through (46), the F(NP-object) is moved obligatorily to the right of its verb. The structural constraint which is imposed on these sentences varies from one sentence to another. In (42a), the verb is attached to an F(Pro). In (43a), the MI(NP-subject) is a complex clause which begins with the complementizer ?an. In (44a), the MI(subject) is restricted by the particle ?illā, which narrows down the action done by ?Amr^c. The movement of the MI(NP-subject) to its expected position in (44b), however, will result in a grammatical structure, but with a different semantic structure. In (45a), a pronoun which is coreferential with the F(NP-object) is attached to the MI(subject), i.e., rabbu. In (46a), the MI(NP-subject) is a relativized clause which cannot precede the F(NP-object). Thus, the above structures have the underlying structure which is presented in (47).

(47)

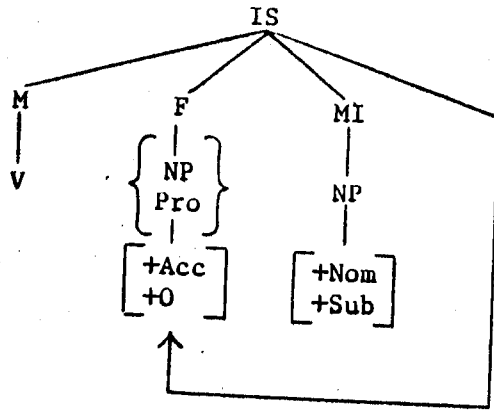

The constraint on Movement rule can be shown in different structures in Arabic, where the constituents cannot move, even though these structures are not ambiguous. The constraints on Movement rule come from other factors, which can be illustrated in the following examples.

(48) a. $\begin{array}{ccc} \text{M} & \text{MI} & \text{F} \\ \boxed{\quad} & \boxed{\quad} & \boxed{\quad} \\ \text{ḍarab} - \text{tu} & \text{zaydan} & \\ \text{hit} & \text{I} & \text{Zayd} \\ \text{I hit Zayd.} \end{array}$

b.* $\begin{array}{ccc} \text{ḍarab} & \text{zaydan} & \text{tu} \\ \underline{\quad} & \underline{\quad} & \underline{\quad} \end{array}$

(49) a. $\begin{array}{cccc} & \text{M} & \text{MI} & \text{F} \\ & \boxed{\quad} & \boxed{\quad} & \boxed{\quad} \\ \text{mā} & \text{ḍaraba} & \text{ḥamrun} & \text{ʔilla} & \text{zaydan} \\ \text{Neg} & \text{hit} & \text{ḥAmr} & \text{except} & \text{Zayd} \\ \text{ḥAmr hit nobody except Zayd.} \\ \text{(ḥAmr did not hit other people.)} \end{array}$

b.* $\begin{array}{cccc} \text{mā} & \text{ḍaraba} & \text{zaydan} & \text{ʔilla} & \text{ḥamrun} \\ \underline{\quad} & \underline{\quad} & \underline{\quad} & \underline{\quad} & \underline{\quad} \end{array}$
(Nobody hit Zayd except ḥAmr.)

- (50) a.

M	MI	F		
kariha	^c amrun	mā	ʔaḥabba	zaydun
disliked	^c Amr	what	liked	Zayd

^cAmr disliked what Zayd liked.

b.* kariha mā ʔaḥabba zaydun ^camrun

The constraint in moving constituents in (48), (49), and (50) is that the subject in (48a) is an MI(Pro) which must be attached to its verb. The MI(NP-subject) in (49a) is ^cAmr, to whom the action of hitting is restricted; thus it might be to the right of the verb, otherwise, the structure would be grammatical but with a different semantic reading. In (50a), the F(NP-object) is a complex structure which cannot move to the right of the verb.

It seems that structures which have no syntactic or semantic constraint allow Movement. The rule which can capture the freer and more restricted movement of the constituents might be represented in the following rules.

(51) a. [Y...M(V)...MI(NP)...F(X)...Z]
 1 2 3 4 5

b. [1...[4+2]...3...∅...5]

c. [1...[2+4]...3...∅...5]

X = must be free from any syntactic and semantic restrictions.

2.1.2. Constraints on Unified Category and ?al-?i?ti?al
Principles in Verbal Structures

The constraint on Movement rule might come from a general principle which I would like to call the "unified category." According to this principle, if two constituents are dominated by a higher category, Movement rule must move the whole higher category and not its lower constituent. In other words, the transformation must move a major category, but not a minor category under a certain domination.

Arabic has five syntactic categories, each of which forms one higher category which dominates two lower constituents. The process of Movement within a particular category must move the higher category but not the lower one; otherwise, the structure of the sentence would be ungrammatical. The unified categories can be listed as follows:

(52)

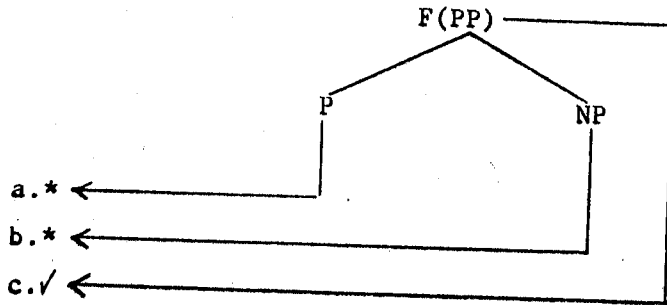

(53)

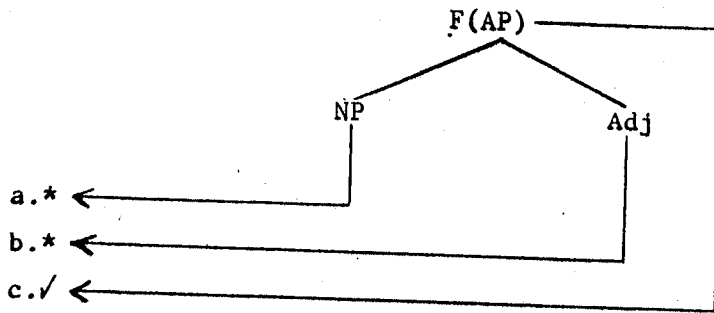

(54)

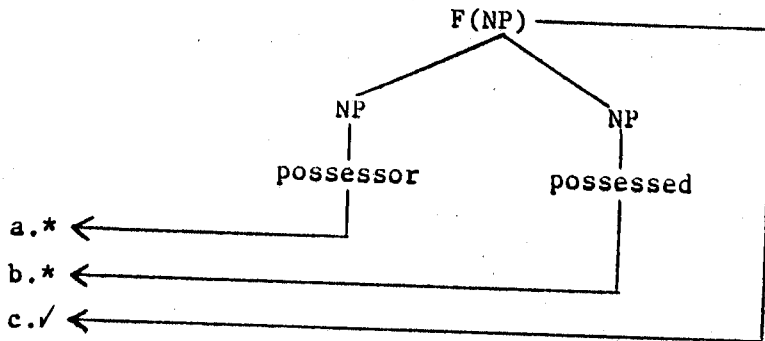

(55)

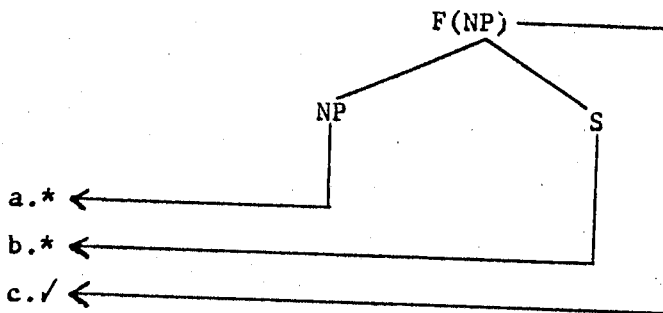

(56)

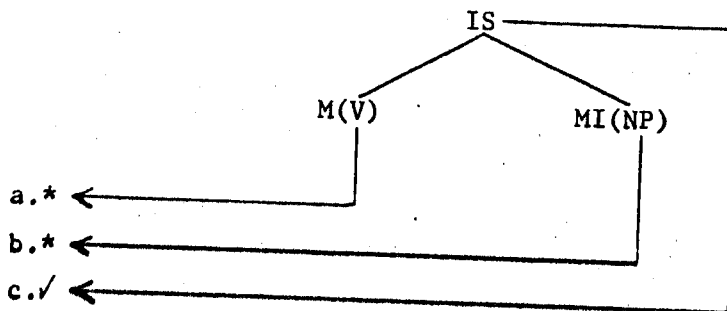

Let us consider the following examples.

- (57) a. ?i^C tamada zaydun ^C alā ta?abbatašarran^V
 depended Zayd on Ta?abbatašarran^V
 Zayd depended on Ta?abbatašarran^V.
- b. ^C alā ta?abbatašarran^V ?i^C tamada zaydun
 on Ta?abbatašarran^V depended Zayd
 On Ta?abbatašarran^V Zayd depended.
- c.* ta?abbatašarran^V ?i^C tamada zaydun ^C alā ∅
- (58) a. jalasa zaydun ^C alā l-kursiyyi
 sat Zayd on the chair
 Zayd sat on the chair.
- b. ^C alā l-kursiyyi jalasa zaydun
 on the chair sat Zayd
 On the chair Zayd sat.
- c.* l-kursiyyi jalasa zaydun ^C alā ∅
- (59) a. qatala sayfubnu^{X-}ūiyazana malika l-fursi
 killed Sayfubnu^{X-}ūiyazana king Persia
 Sayfubnu^{X-}ūiyazana killed the king of Persia.
- b. malika l-fursi qatala sayfubnu^{X-}ūiyazana
 king Persia killed Sayfubnu^{X-}ūiyazana
 The king of Persia Sayfubnu^{X-}ūiyazana killed.
- c.* l-fursi qatala sayfubnu^{X-}ūiyazana malika ∅
- d.* malika qatala sayfubnu^{X-}ūiyazana ∅ l-fursi

- (60) a. galaba zaydun ta?abbaṭaxayran wa ta?abbaṭaṣarran
 defeated Zayd Ta?abbaṭaxayran and Ta?abbaṭaṣarran
 Zayd defeated Ta?abbaṭaxayran and Ta?abbaṭaṣarran.
- b. ta?abbaṭaxayran wa ta?abbaṭaṣarran galaba zaydun
 Ta?abbaṭaxayran and Ta?abbaṭaṣarran defeated Zayd
 Ta?abbaṭaxayran and Ta?abbaṭaṣarran Zayd defeated.
- c.* ta?abbaṭaṣarran galaba zaydun ta?abbaṭaxayran wa ∅

As seen in (57c), (58c), (59c/d), and (60c), when a lower constituent is moved to the left of the verb, it will violate the "unified category" principle. Thus the conditions which might be imposed on (57c), (58c), (59c/d), and (60c) can be explained in the following way:

- (61) a. X is all constituents within the verbal structure.
 b. If X is two constituents dominated by a higher node, Movement rule must move the higher node.
 c. Structures which do not meet these two conditions will violate the "unified category" principle.

The most crucial condition about the "unified category" principle is that it must be applied within a verbal structure. The violation of such principle in certain cases will result in a nominal structure which might be subject to certain constraints which state the following:

- (62) a. A constituent can be in sentence-initial position as MI(topic), but it must have a pronominal copy in the sentential comment.

- b. The (Pro) nominal copy must be coreferential with its antecedent MI(topic).
- c. The antecedent MI(topic) is not dominated by IS of the verbal structure (i.e., $IS \longrightarrow M-MI-F$), but by IS of the nominal structure (i.e., $IS \longrightarrow MI-M-F$).

The difference between verbal structure and nominal structure under the constraints of (62) can be seen in the following examples.

(63) a. marar - tu bi - zaydin

passed I by Zayd

I passed by Zayd.

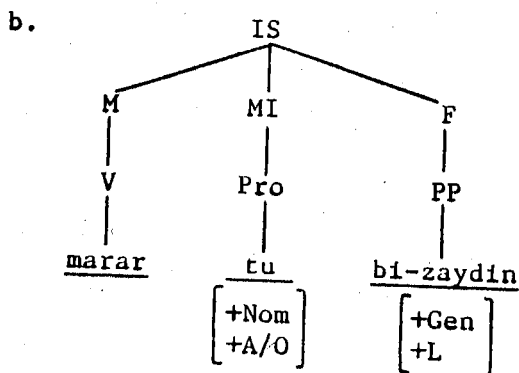

c. zaydun marar - tu bi - hī

Zayd passed I by him

As for Zayd, I passed by him.

d.

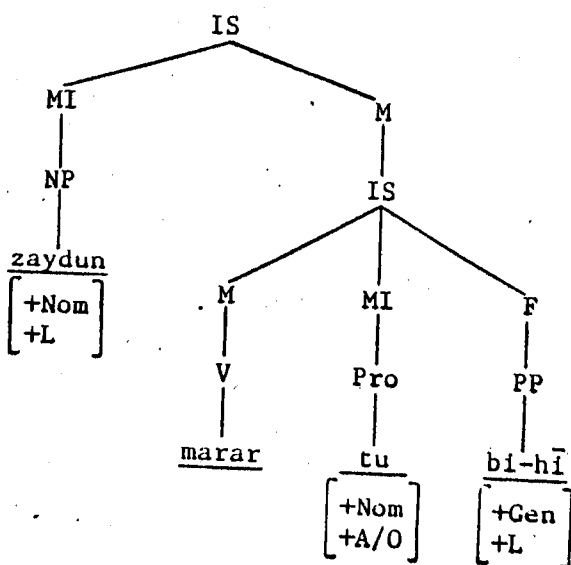

- (64) a. qatala sayfubnuo^{x-}iyazan malika l-fursi
 killed Sayfubnuo^{x-}iyazan king Persia
 Sayfubnuo^{x-}iyazan killed the king of Persia.

b.

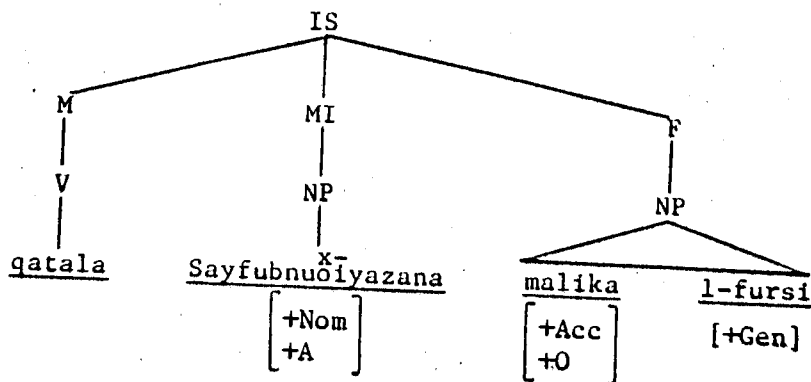

- c. ?al-fursu, qatala sayfubnuo^{x-}iyazan malika - hum
 the Persians killed Sayfubnuo^{x-}iyazan king their
 As for the Persians, Sayfubnuo^{x-}iyazan killed their king.

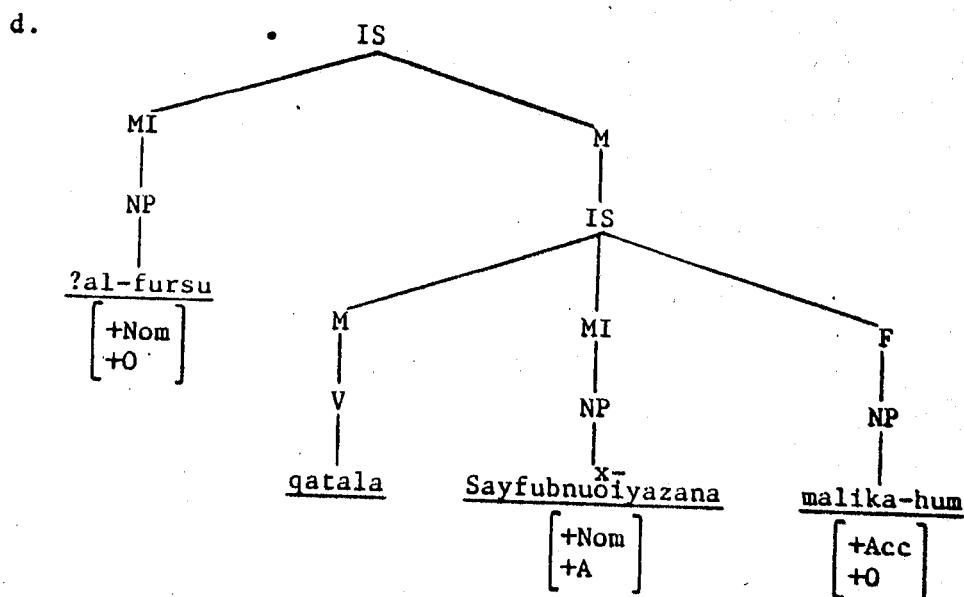

The constraints on the "unified category" principles lead us to discuss similar phenomena within the verbal structure. As seen before, Movement rules can move constituents freely or restrictively. There is another process in the Arabic language where the F(NP-object) is moved to an initial position in the verbal structure, leaving a pronominal copy attached to the verb. The pronominal copy must be coreferential with its antecedent F(NP-object) which is at the beginning of the structure controlled by IS-node. This syntactic process was called in Arabic ?al-?i^Ystig^Yal. The strict translation is 'busyness,' i.e., the verb will be so busy operating on the pronominal copy or the resumptive pronoun that it cannot operate on the initial F(NP-object). This is possible in question formation, question-like formation, imperative, negative, and conditional clauses. The syntactic operation of ?al-?i^Ystig^Yal in

the underlying structure of the verbal sentence is exhibited in the configurations presented in (65).

- (65). a. ?a zaydan darabta-hu ∅-Pro ?
 Q Zayd hit him you
 As for Zayd, did you hit him?

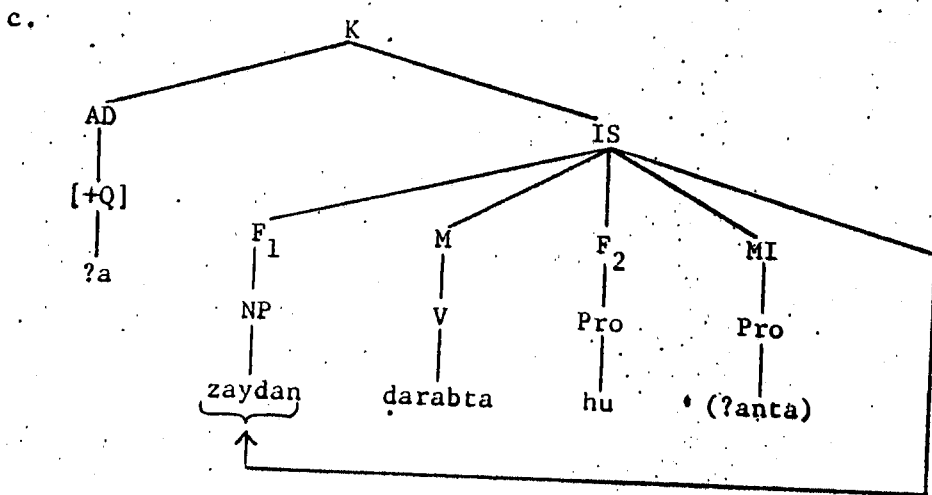
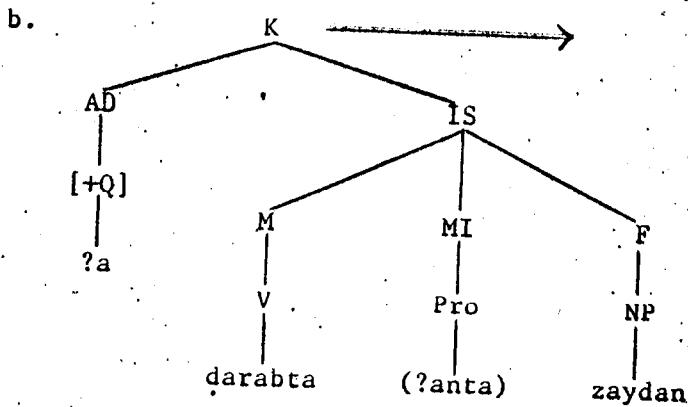

This is different, however, from the MI(NP-object) which can be in a nominal structure and will be within the domain of the nominal structure. In the new process, the F(NP-object) will be operated on by what Arab grammarians had called bi-fi^Clin muqaddarin yufassiru-hu mā ba^Cda-hu, i.e., a covert verb interpreted by a verb that comes after

it. The crucial constraint on such a syntactic process is that it must occur in question formation, question-like formation, imperative, negative, and conditional clauses.

Let us exemplify this syntactic phenomenon with the following examples.

- (66) ?a zaydan darabta-hu → Q-formation
 Q Zayd hit him
 As for Zayd, did you hit him?
- (67) hallā zaydan tukrim-hu → Q-like formation
 A-like Zayd honor him
 As for Zayd, would you please honor him.
- (68) ta?abbataxayran ?akrim-hu → Imperative
 Ta?abbataxayran honor him
 As for Ta?abbataxayran, honor him.
- (69) ta?abbata^Vsarran lā tukrim-hu → Negation
 Ta?abbata^Vsarran Neg honor him
 As for Ta?abbata^Vsarran, don't honor him.
- (70) ta?abbata^Vsarran ?in tukrim - hu yatamarrad → Condition
 Ta?abbata^Vsarran if you honor him rebel
 As for Ta?abbata^Vsarran, if you honor him, he will rebel.

The above examples show a certain syntactic process where the F(NP-constituent) is moved to the left of the verb, leaving a pronominal copy attached to the verb. The F(NP-object) is coreferential with its resumptive pronominal copy F(Pro).

2.2. Word Order in Nominal Structures

The nominal structure has three types in Arabic. The first type consists of MI-topic and verbal sentence-comment. The second type consists of MI-topic and nominal existential sentence-comment. The third type consists of MI-topic and M (i.e., NP, AP, PP, or AdvP)-comment. In this section, I will explain the structures of types one and two.

2.2.1. Nominal Structures

Nominal structures are generated in the base. The base is able to generate two types of structures. The first consists of MI(topic), followed by a verbal sentence (comment). The second consists of MI(topic), followed by an existential sentence (comment). The two types can be represented in (71) and (72), respectively.

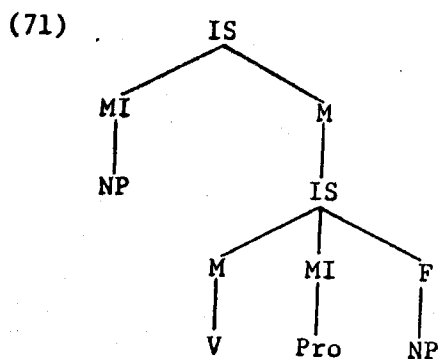

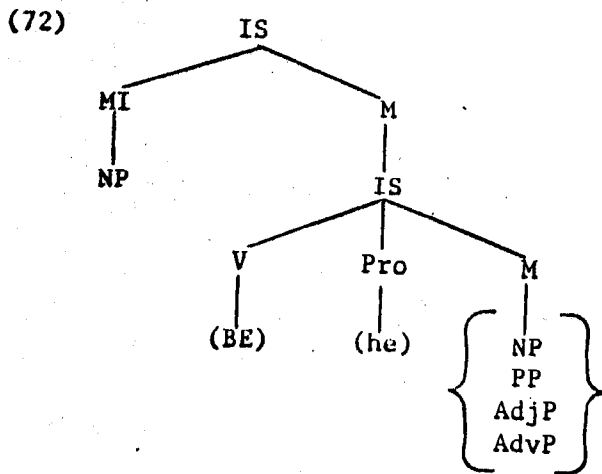

In structures (71) and (72), we have an MI(topic) or (theme) followed by either a verbal sentential clause as in (71) or a nominal existential clause as in (72). The following sentential clause in both structures functions as a theme or comment. The structures in (71) and (72) are subject to transformation, but in a different manner from what we have seen in the verbal structure. Let us consider some examples which can indicate clearly the basic structures and the derived structures.

- (73) a. zaydun daraba ∅-Pro ^cAmran
 Zayd hit he ^cAmr
 As for Zayd, he hit ^cAmr.

b.

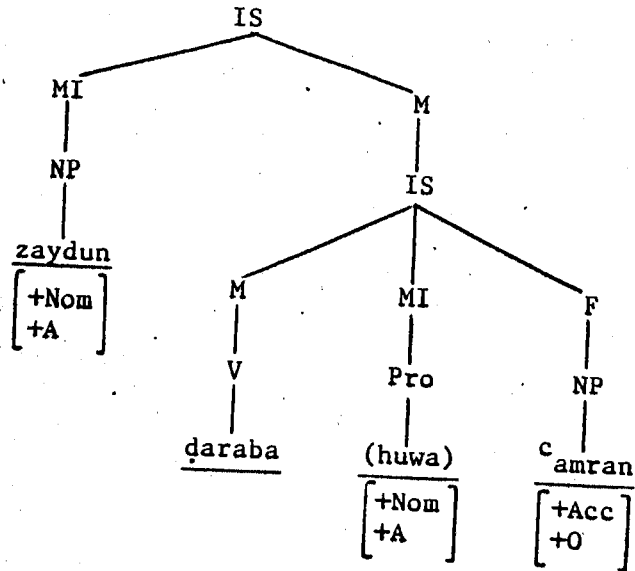

(74) a. $\frac{\text{zaydun}}{\text{Zayd}} \quad \frac{{}^c\text{amran}}{{}^c\text{Amr}} \quad \frac{\text{ḍaraba}}{\text{hit}} \quad \frac{\emptyset\text{-Pro}}{\text{he}}$

b.

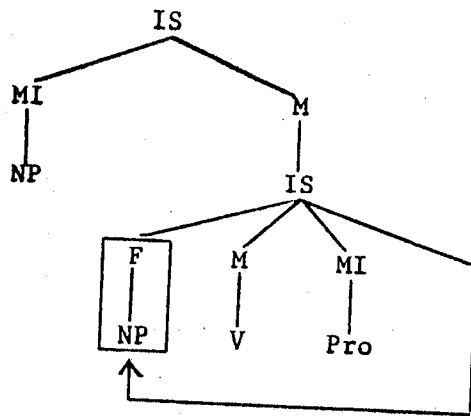

(75) a. $\frac{\text{zaydun}}{\text{Zayd}} \quad \frac{?abū - hu}{\text{father his}} \quad \frac{v-c \text{ irun}}{\text{poet}}$
 As for Zayd, his father is a poet.

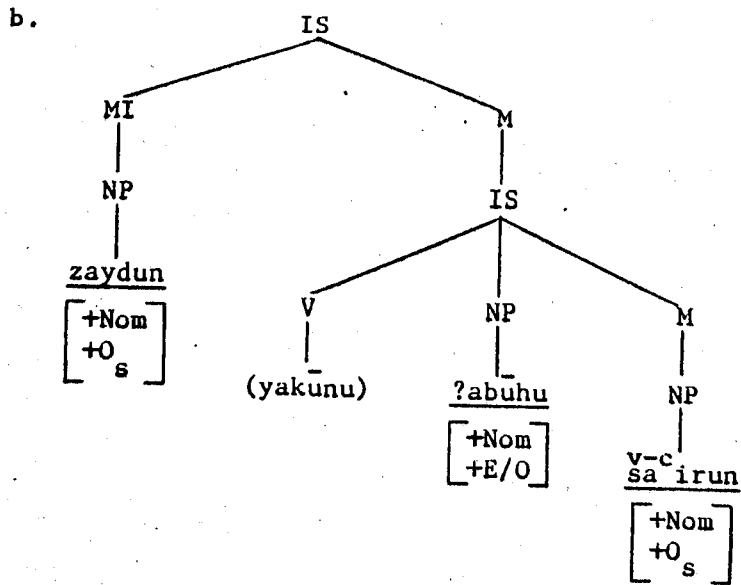

c. zaydun v-c sa irun ?abū - hu
 Zayd poet father his

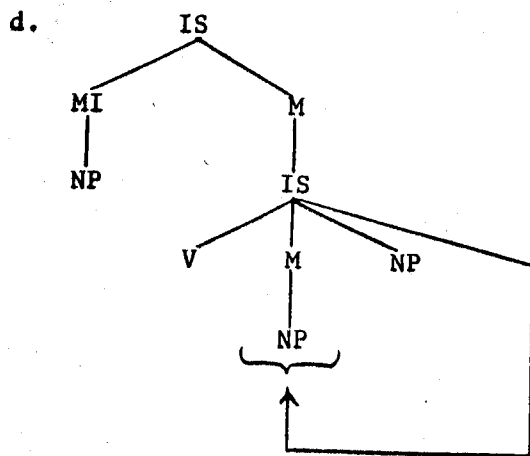

In the above examples, the constituent Zayd is always an MI(NP-topic) which is coreferential with its resumptive covert pronoun which is in the verbal sentential comment as in (73b) and (74b), with its resumptive overt pronoun which is in the nominal sentential comment as in (75b). The MI(NP-topic) is base-generated constituent, whereas the

other constituent such as ^CAmr F(NP-object) in the verbal structure and ^{V-C}sa'irun M(NP) in the nominal structure are transformationally moved.

Thus the most important aspect in the nominal structure is that the sentential comment must contain a resumptive pronoun which is sometimes covert (i.e., an empty pronoun) and sometimes overt (i.e., a full lexical pronoun).

The comparison between the MI(NP-topic) and the F(NP-object) leads us to the following syntactic and semantic properties for each.

(76) MI(NP-Topic)

- a. It is basically a base-generated constituent.
- b. It has a case marker of nominative.
- c. It has a resumptive pronoun in the sentential comment.
- d. It is followed by a sentential comment either verbal or nominal.
- e. It is coreferential with the resumptive pronoun.
- f. Movement can take place in the sentential comment and move some constituents transformationally.

(77) F(NP-Object)

- a. It is transformationally moved.
- b. It has a case marker of accusative.
- c. It occurs in a verbal sentential structure.
- d. It does not have a resumptive pronoun except in a ?al-?i^Vstigal^{V-} phenomenon.

- e. When it has a resumptive pronoun, it is coreferential with it.
- f. It moves to a position either to the right of the verb or to the left of the verb.

2.2.2. Nominal Existential or Equational Structures

The third type of the nominal structures is the equational or existential structure. The theoretical framework of the equational or existential sentence varies among linguists, depending on the approach which they adopt. Snow (1965), Killean (1964), Lewkowicz (1967), and Awwad (1973) have analyzed the structural framework of the equational sentence within the word order of (SVO). According to Bakir (1980), the theoretical framework of the equational sentence for the past decades was as in (78) and (79).

(78) S \longrightarrow NP - VP

(79) VP \longrightarrow $\left\{ \begin{array}{l} V - (NP) (PP) (AdjP) (AdvP) \\ V - Cop - NP \end{array} \right\}$

Bakir (1980) and Fihre (1981) deviated from the above framework and perceived the structure of the equational sentence from a different perspective. They considered the structure of the equational sentence to be within the word order of NP-(V)-NP. In their framework, they proposed a verb-deletion rule which can delete the existential verb yakūnu, 'be' in the present, and keep it in the past kāna and future tense sayakūnu.

In this study, however, I shall analyze the structure of the equational sentence within the framework which I proposed before. This means that the equational structure consists of two constituents. The first is the starting constituent MI-topic, which might be (NP), (VN), or (S). The second is the predicate M-comment which might be (NP), (AP), (PP), (AdvP), or (S). All these categories can be collapsed under one category, M(X), i.e., a predicate X. Thus, assuming these constituents, the structure of the equational sentence can be analyzed as in (80).

(80) [IS.....MI.....M(X)]

Condition: V = is always deleted in the equational structure except when it is in the past and future tense, i.e., (kāna = was, sayakūnu = will be)

The constraint on such structures in Ibn ya^Ciš's terminology is that M represents three existential verbs:

- (81) a. yakūnu _____ i.e., BE
 b. yastaqirru _____ i.e., EXIST
 c. yaḥduṯu _____ i.e., HAPPEN

The two verbs in (81b) and (81c) must be deleted in any syntactic environment of the equational sentence. The verb in (81a) must be deleted only if it is in the present tense. This means that the verb yakūnu 'BE' is not deleted in the past and future tense. The category (X) (i.e., NP, AP, PP, AdvP), however, must take the position of the deleted verb and function exactly as if it were that V.

Putting what Ibn ya^ci^s had stated in our modern theoretical framework, we can have the following lexical properties of the deleted and substituted verb in the equational structure.

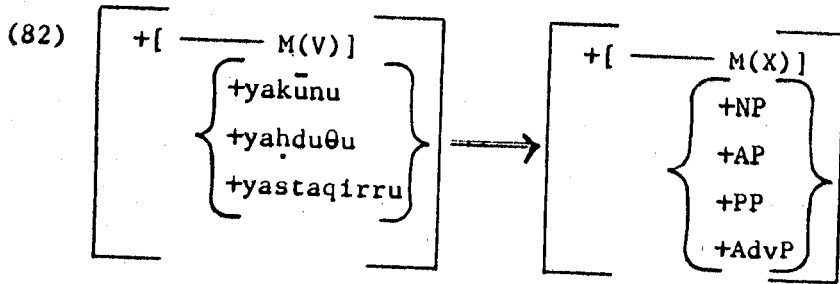

The configurational structures of the equational sentences in (83) and (84) are shown in (85a) and (85b).

(83) zaydun fī d - dāri
 Zayd in the house
 Zayd is in the house.

(84) zaydun *(yakunu huwa) fī d - dāri
 Zayd is he in the house
 As for Zayd, he is in the house.

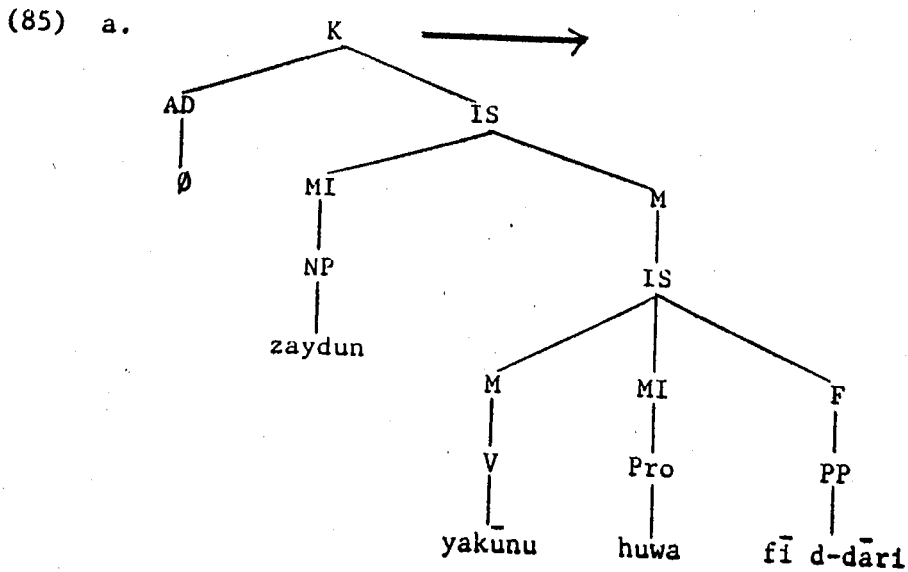

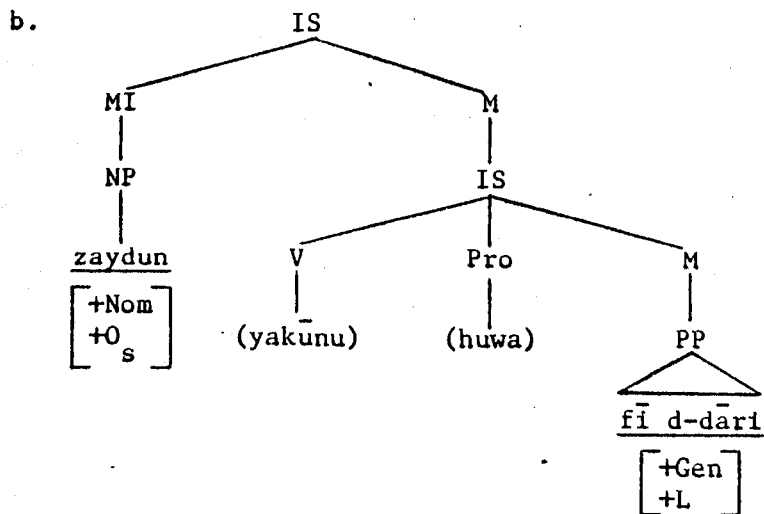

Thus, the general structure of the existential sentence might be represented in the following structures.

- (86) a. zaydun sa^{v-c} irun
 Zayd poet
 Zayd is a poet.

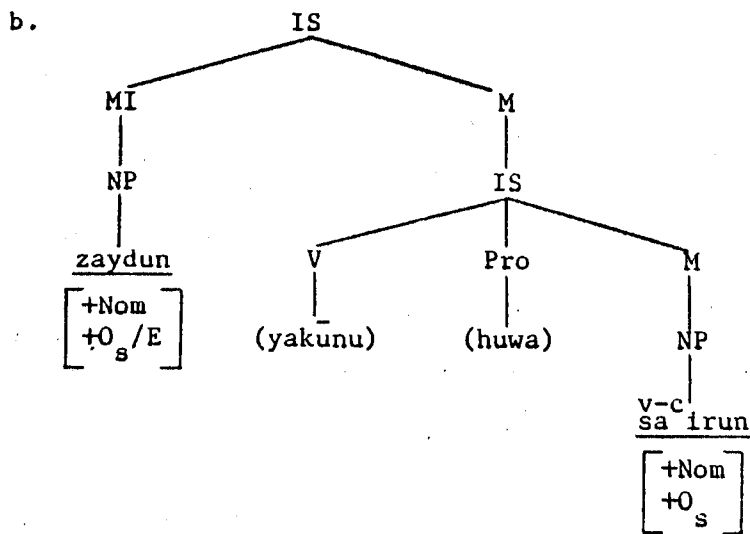

- (87) a. amrun ḥalimūn
^cAmr patient
^cAmr is patient.

b.

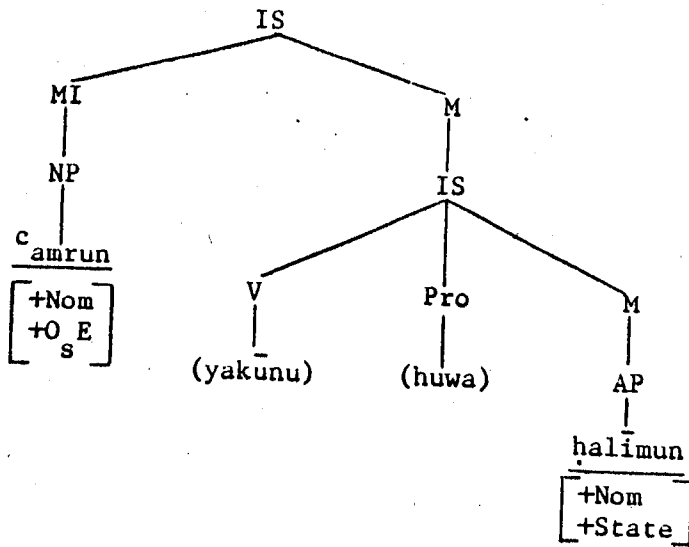

- (88) a. ta?abbaṭaṣarran fī d - dāri
 Ta?abbaṭaṣarran in the house
 Ta?abbaṭaṣarran is in the house.

b.

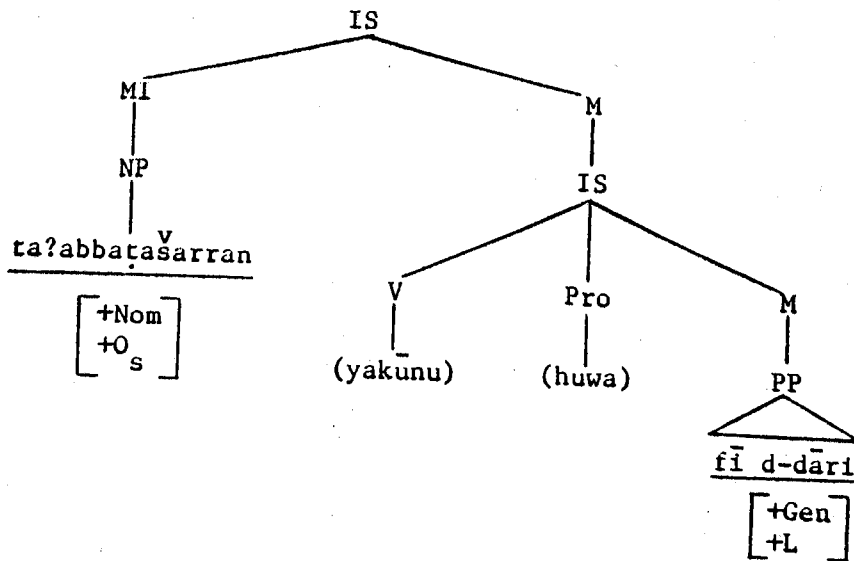

- (89) a. xamrun li-yawmin (wa ?amrun li - ḡādin)
 wine for today and business for tomorrow
 Wine is for today (and business is for tomorrow).

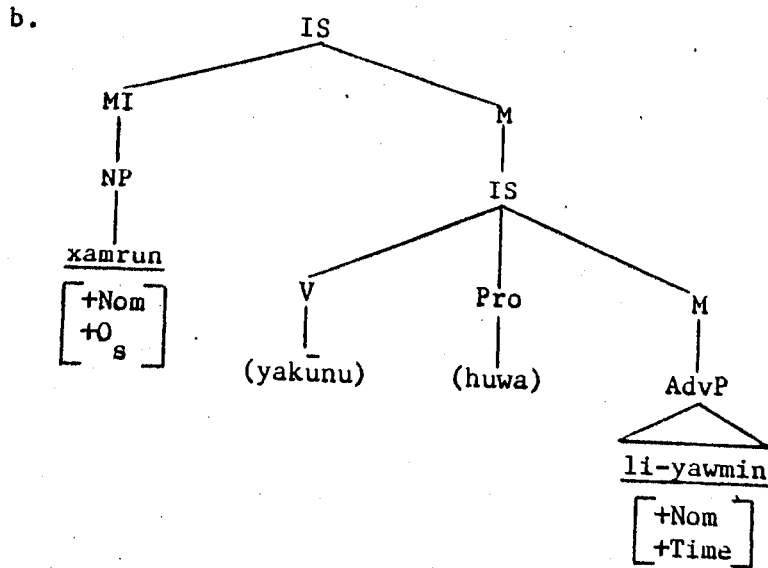

The equational structures above are subject to transformations, but the only constituent which can move is the predicate constituent, i.e., M(X). The only constraint on the operation of transformation is that the category M(X) must be indefinite. The idea behind this constraint is semantic and syntactic because when the category M(X) is definite and it is at the beginning of the structure, the process will have nothing to do with transformation. The definite M(X) would be generated in the base to the left of its MI(NP-argument). In addition, the meaning of the sentence will be narrowed down to focus on the constituent which is at the beginning of the structure, i.e., M(X). For example, if there is no hero, let us say, except Sayfubnu^Xiyazan, we can attach this quality to that person by generating the M(X) in the base as it is shown in (90) and (91).

- (90) a. sayfubnu^{x̄}iyazana baṭalun
 Sayfubnu^{x̄}iyazana hero
 Sayfubnu^{x̄}iyazana is a hero.

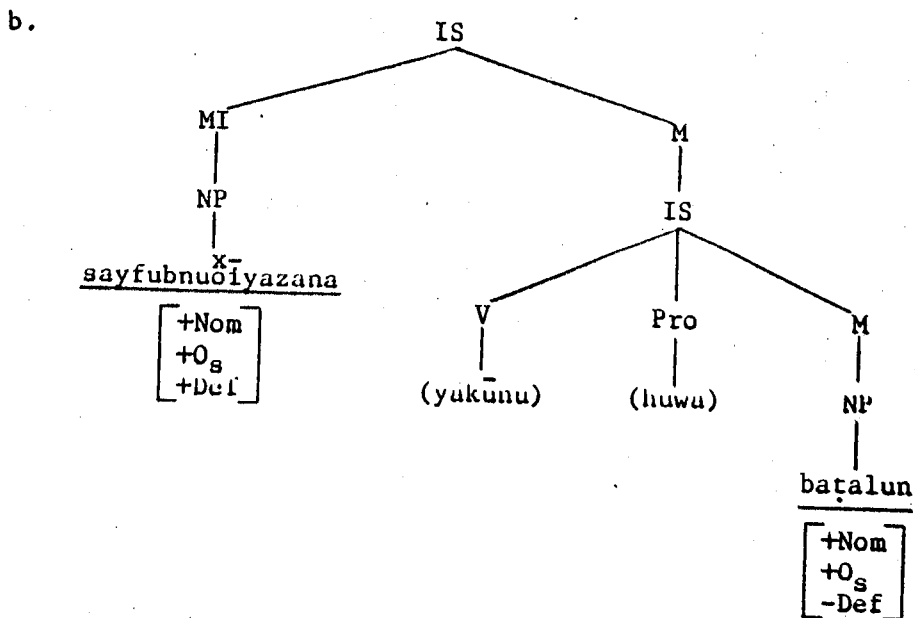

- (91) a. ?al-baṭalu sayfubnu^{x̄}iyazana
 hero Sayfubnu^{x̄}iyazana
 As for the hero, he is Sayfubnu^{x̄}iyazana.

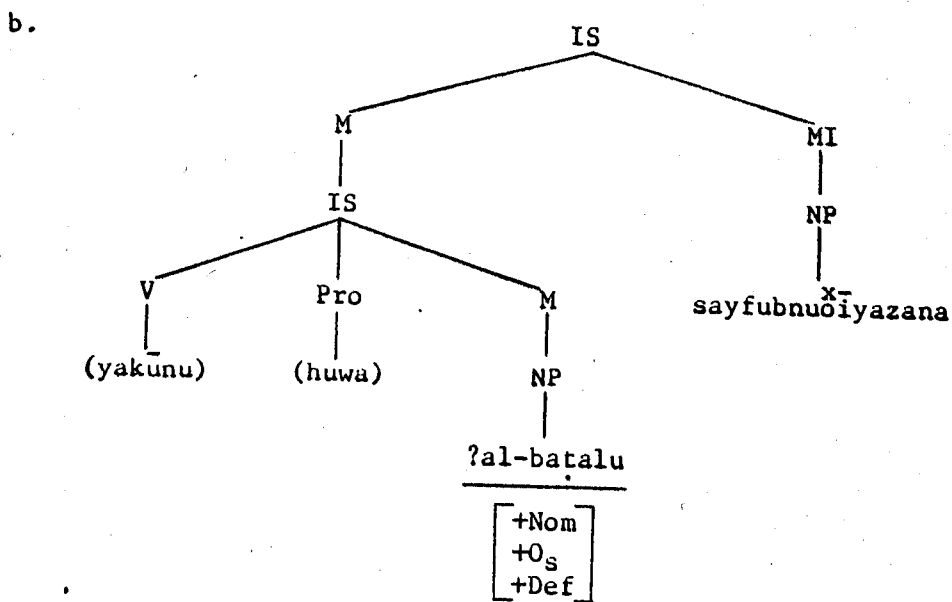

The basic structure and its transformations in the equational sentence are as in (92) and (93).

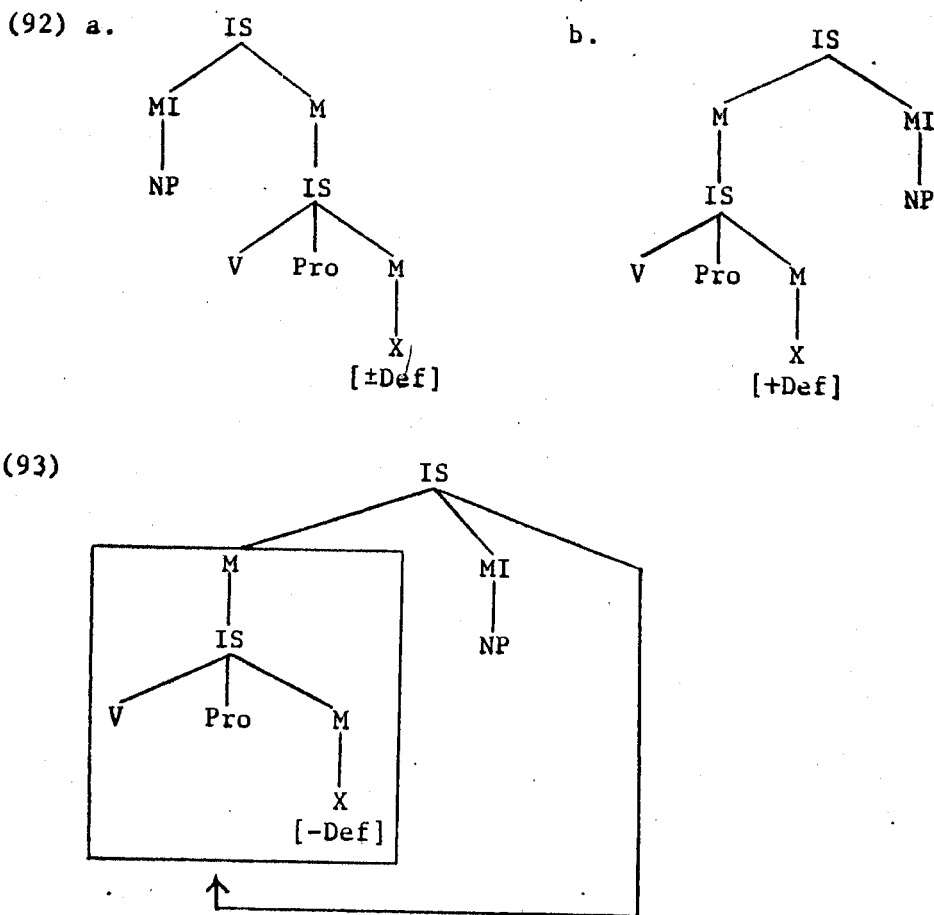

As seen in the above structures, the category $M(X)$ is either to the right or to the left of $MI(NP)$ in the base. The condition for its initial position in the base is that it must be definite. But when it is transformed, it must be indefinite.

The operation of Movement on the basic structure of the equational sentence can be shown when we transform the structures (86b), (87b), (88b), and (89b) to the structures (94a/b), (95a/b), (96a/b), and (97a/b).

(94) a. $\frac{v-c}{\text{sa}^c \text{irun}}$ $\frac{\text{zaydun}}$
 poet Zayd
 Zayd is a poet.

b.

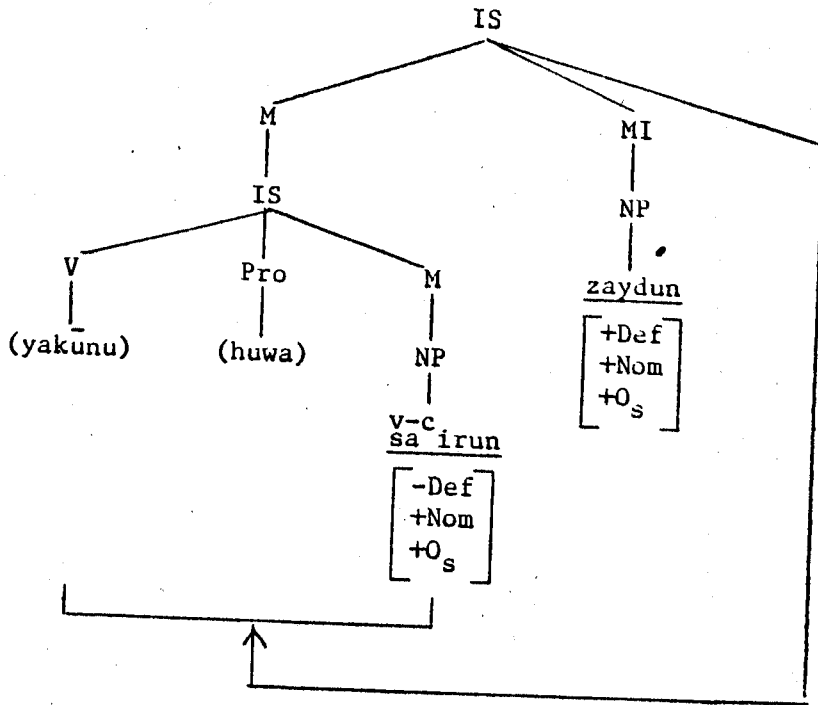

(95) a. $\frac{\text{halimun}}{\text{patient}}$ $\frac{c}{\text{amrun}}$
 $\frac{c}{\text{Amr}}$
 $\frac{c}{\text{Amr}}$ is patient.

b.

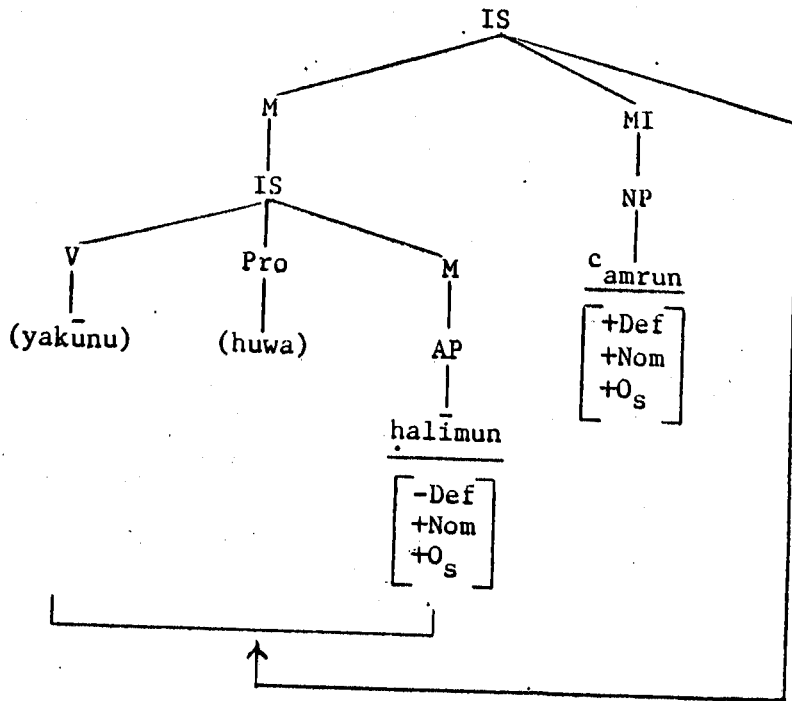

- (96) a. fī dārin taʔabbaṭasarran
 in house Taʔabbaṭasarran
 Taʔabbaṭasarran is in a house.

b.

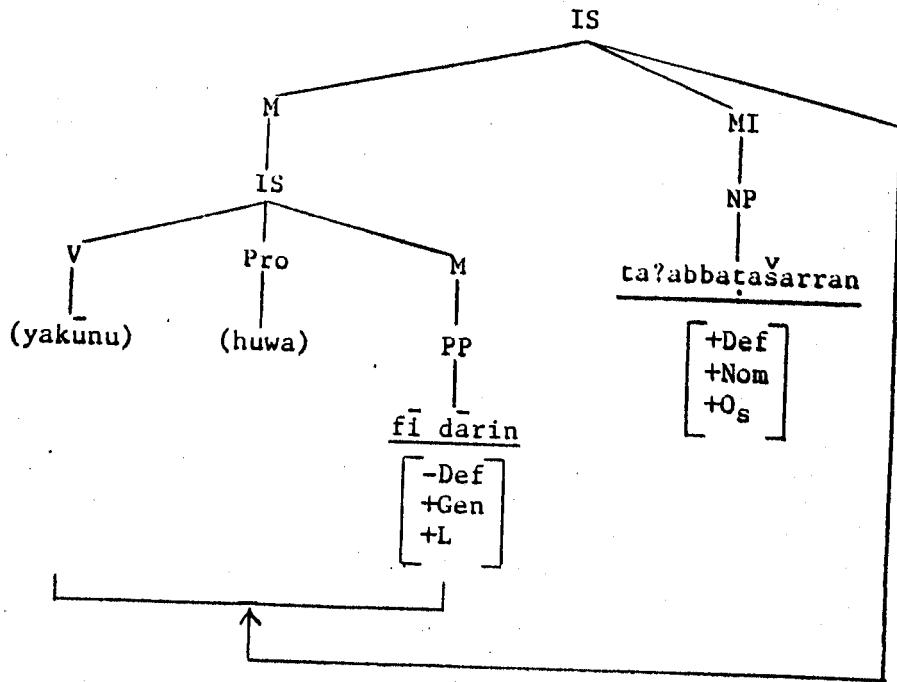

- (97) a. yawmun li - xamri (wa yawmun li - ?amri)
 one day for the wine and other day for the business
 One day is for the wine (and the other day is for
 the business).

b.

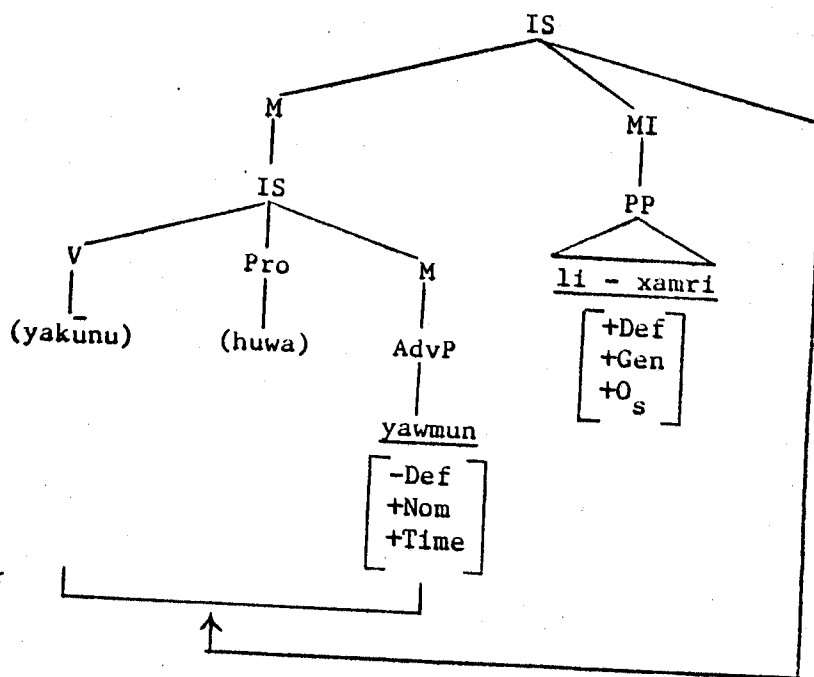

As seen in the above examples, the indefinite category M(X) is preposed to the left of its MI(NP-argument) by the operation of Movement which will move M(X) to the front of the structure.

Summing up, Arabic shows four types of basic structures: (a) verbal structure (i.e., M-MI-F), (b) nominal verbal structure (i.e., MI-M-MI-F), (c) nominal existential structure (i.e., MI-MI-M), and (d) existential sentence (i.e., MI-M). These structures are subject to different transformations, some of which need no constraint at all, and some of which must be constrained in order to generate grammatical structures.

CHAPTER FOUR
QUESTION STRUCTURES

0. Introduction

In this chapter, I shall investigate the sentence structures of question formation in Arabic. The investigation will cover two types of question formation: the first type is na^cam-lā 'yes-no' question. I intend to describe the general characters of the Yes-No-Q, and I will study the syntactic and semantic aspects associated with this type of question formation.

The second type is the Information-Question (henceforth I-Q). The structure of this type will also be examined. The investigation, however, will draw its theoretical framework from the general principles of transformational rules. These transformational rules will be applied to the verbal and nominal structures. The study will consequently propose some syntactic and semantic constraints which are able to restrict the movement of a category in the generation of grammatical structures. In addition, I will propose that some structures need no Q-movement at all.

1. The Theoretical Framework of the Yes-No-Question

The Yes-No-Q in Arabic has roughly the same structure as the basic sentence. The only difference between these two structures is that the question particles which are used

in such a structure are generated under the AD-node. The question particles in Arabic change or transform the basic structure into a question structure. The phrase-structure rules of the Yes-No-Q are basically drawn from the general framework proposed in previous chapters. These rules are presented in (1).

- (1) a. $K \longrightarrow AD-IS$
 b. $AD \longrightarrow \pm Q$
 c. $+Q \longrightarrow \begin{Bmatrix} ?a \\ hal \\ \emptyset \end{Bmatrix}$
 d. $IS \longrightarrow \begin{Bmatrix} M-MI-F \\ MI-M-F \end{Bmatrix}$

The configurations (2) and (3) represent the underlying structure of the Yes-No-Q in both verbal and nominal sentences.

- (2) a. $\frac{\begin{Bmatrix} ?a \\ hal \end{Bmatrix}}{Q} \quad \frac{daraba}{hit} \quad \frac{zaydun}{Zayd} \quad \frac{{}^c amran}{{}^c Amr} \quad ?$
 Did Zayd hit ^cAmr?

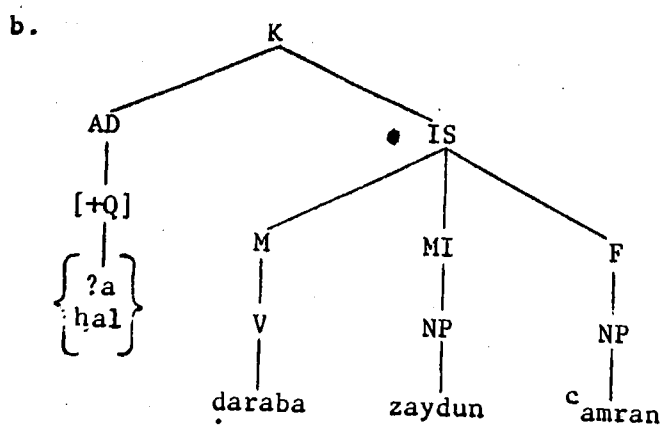

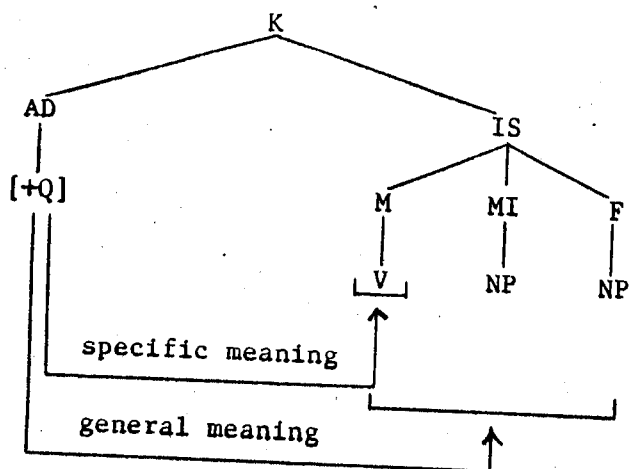
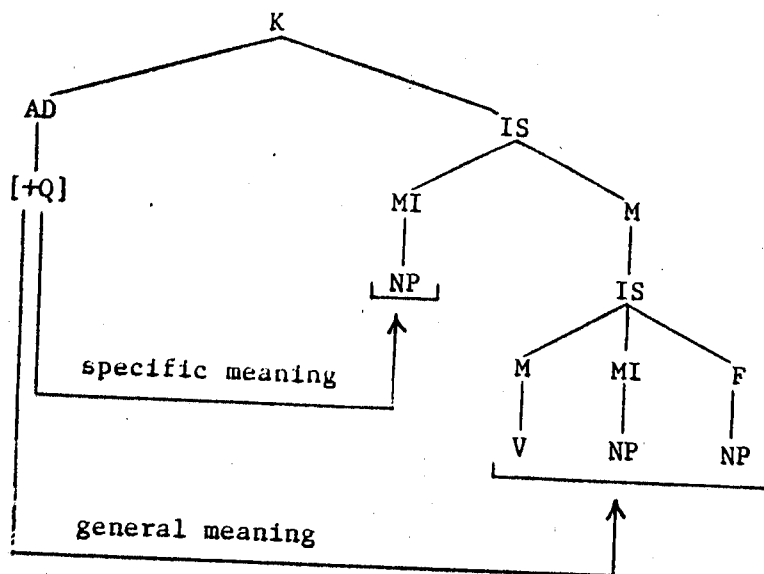
(5) Verbal Structure(6) Nominal Structure

Configurations (5) and (6) show that the transformational particles have two semantic operations; the first operation is to change the general meaning of declarative structure to a question structure. The second operation is to specify the constituent which the question bears on. This issue

will be discussed in detail in later sections concerning the semantic aspects of the Yes-No-Q, but the important point here is that the question particles are considered to be transformational devices whose function is considered to be semantic.

1.1. The Syntactic Aspects of the Yes-No-Question

Arabic uses two transformational particles to express a Yes-No-Q. These particles are ?a and hal. They function as semantic devices, i.e., they occur in the declarative structure to transform it into a question. These two particles share general characteristics, while at the same time they differ from each other in certain structures. These similarities and differences will be discussed here.

The most important characteristic is that they both occur in verbal structure, nominal verbal structure, and nominal equational structure. This can be illustrated in the following examples.

- (7) a. $\left. \begin{array}{l} ?a \\ hal \end{array} \right\} \quad \underline{qāma} \quad \underline{zaydun} \quad ?$
 Q stood up Zayd
 Did Zayd stand up?

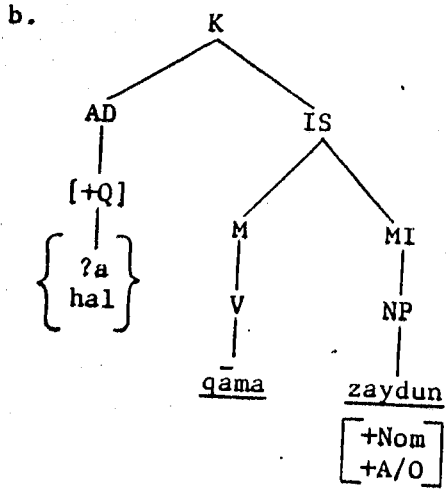

(8) a. $\left\{ \begin{matrix} ?a \\ hal \end{matrix} \right\}$ zaydun qāma ∅-Pro ?
 Q Zayd stood up he
 As for Zayd, did he stand up?

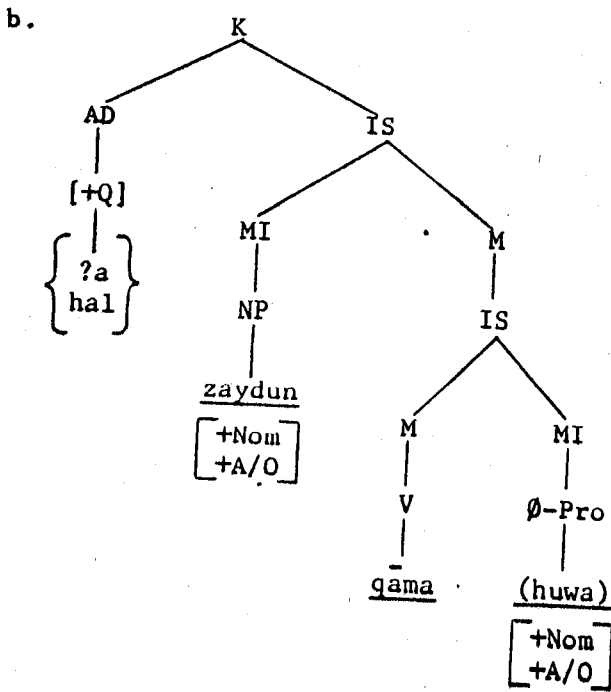

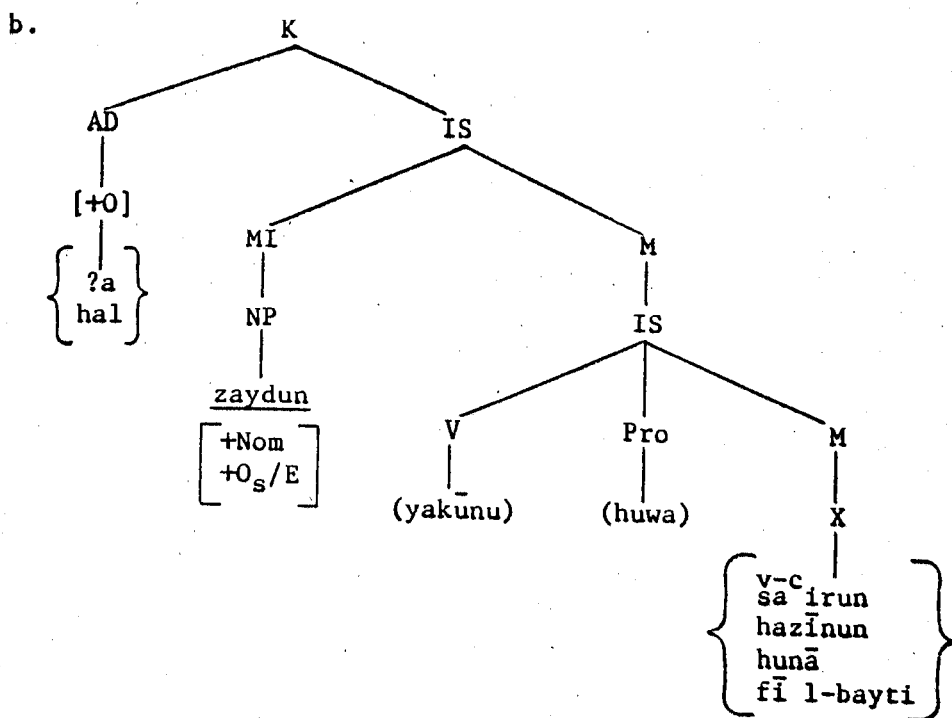
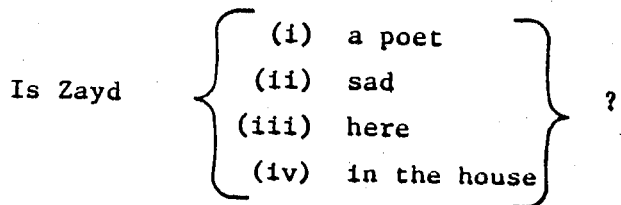
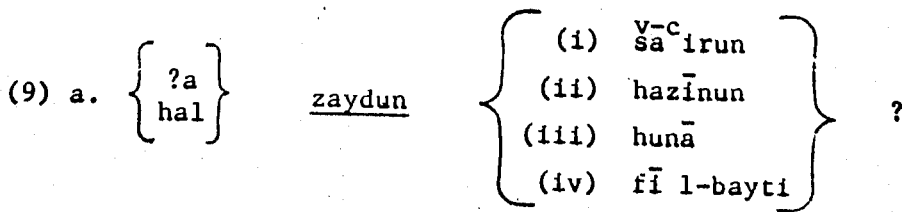

- c. X syntactically = NP, AP, AdvP, and PP
- X semantically = [+State] or [+Locative]

As seen in the above examples, both ?a and hal can syntactically occur in a verbal structure as in (7a), a nominal verbal structure as in (8a), and a nominal equational structure as in (9a). Semantically, however, they operate

on two syntactic constituents to generate a general and specific meaning.

There is another characteristic which ?a and hal share, and that is that they may be deleted from the structure. Ibn Hišām (d. 1368) stated that the question particle may be deleted even though it changes the structure from a declarative to a question. He cited the following examples.

- (10) a. θumma qālū : tuḥibbu-hā ∅-Pro ?
 then they said love her you
 Then they said: Do you love her?

The actual structure is ?a tuḥibbu-hā. Note that one can understand the sentence (10a) as being a question formation from the intonation residing in tuḥibbu-hā. The underlying structure would be in (10b).

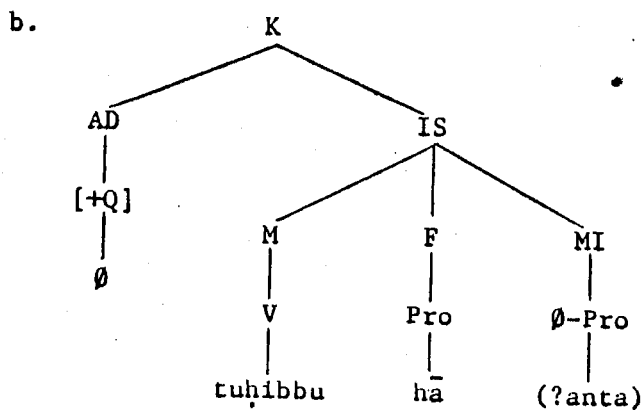

But despite the fact that ?a and hal usually may appear in the same environment, there are some environments in which only one may appear. These constraints can be exhibited in the following examples.

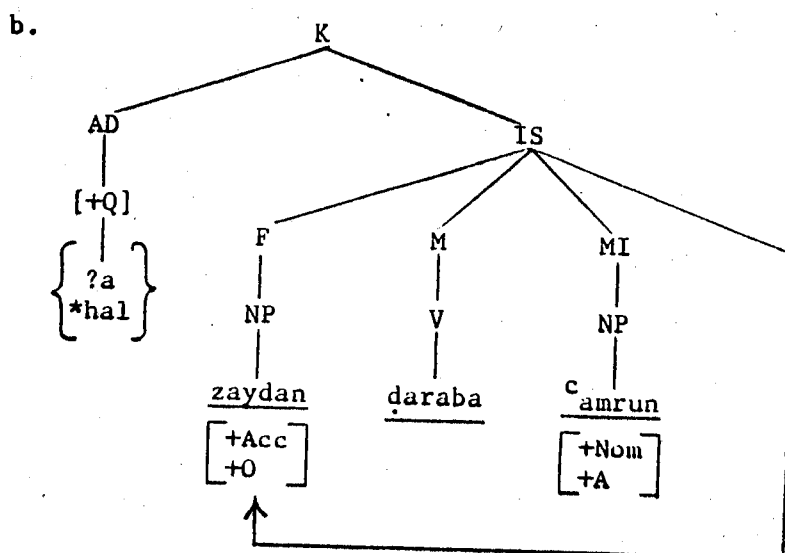

The F(NP-object) in (13b) cannot be preposed to the left of its verb when the Yes-No-Q particle is hal. This is not the case when the Yes-No-Q particle ?a is present in the structure. However, the F(NP-object) can be preposed not only to the left of its verb but also to the left of the Yes-No-Q particle ?a itself. This means that transformational rule can move the F(NP-object) crossing over the AD-position to reach the initial clause position. This is possible, however, if and only if the Yes-No-Q particle is ?a, as shown in (14a) and (14b).

- (14) a. $\frac{\text{zaydan}}{\text{Zayd}}$ $\left\{ \begin{array}{l} ?a \\ *hal \end{array} \right\}$ $\frac{\text{daraba}}{\text{hit}}$ $\frac{{}^c\text{amrun}}{{}^c\text{Amr}}$?
 Is it Zayd that ${}^c\text{Amr}$ hit?

b.

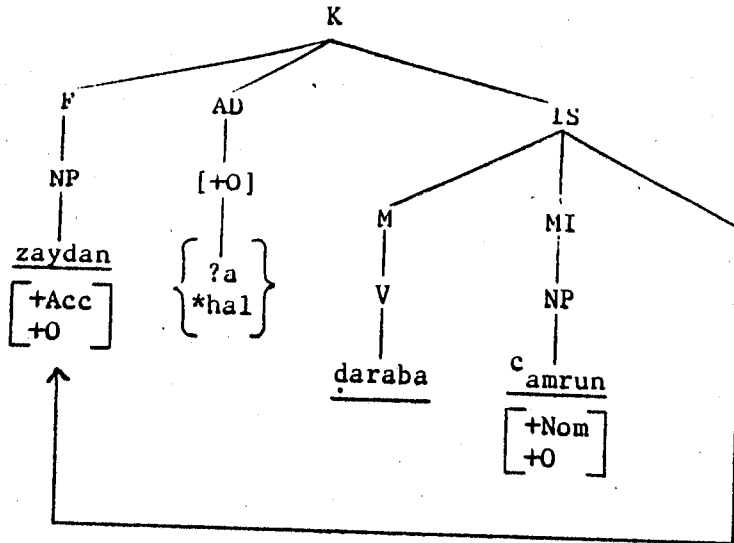

A transformational rule, however, can move more than one constituent from the right of the verb to the left. Once again, the only Yes-No-Q particle which can appear in such preposing process is ?a. ?Al-?Istrābā^Xī (d. 1289) stated that the F(object) and the F(AdvP) can both be adjacent to the Yes-No-Q particle ?a. This can be seen in the following example.

- (15) a. $\left\{ \begin{array}{l} \bar{?a} \\ *hal \end{array} \right\}$ l-yawma zaydan daraba ^camrun ?
 Q today Zayd hit ^cAmr
 Is it today that ^cAmr hit Zayd?

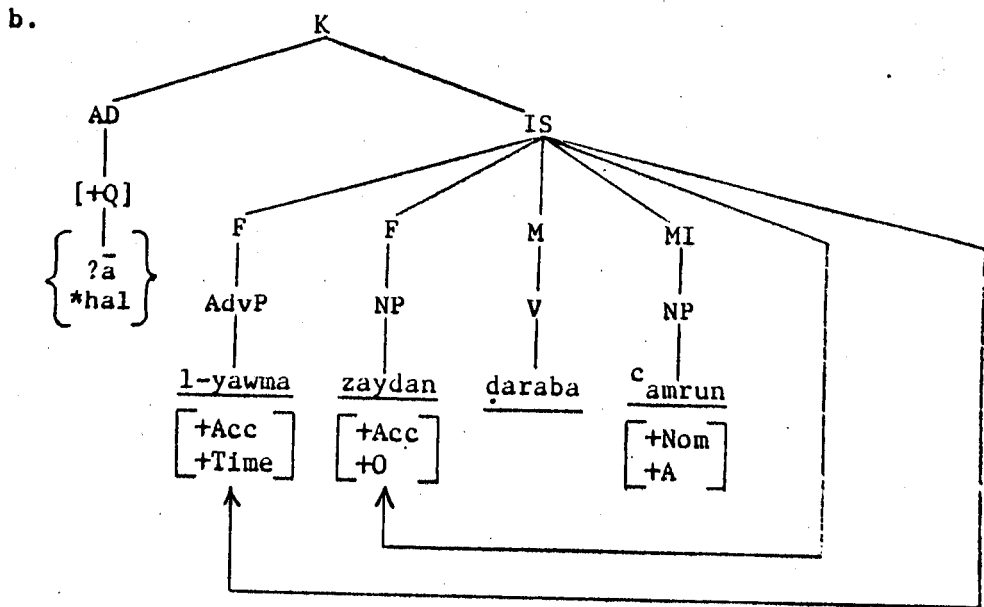

The Arabic structure of Yes-No-Q has the peculiarity that if Speaker 1 says a sentence, Speaker 2 can use the ?a particle along with one constituent from the declarative structure that Speaker 1 produced. Such a structure is used when one would concentrate on a certain constituent as a focus. To form such a question, the structure must meet two constraints:

- (16) a. The only Yes-No-Q particle which can be used is ?a.
 b. The constituent transforming the declarative structure to the Yes-No-Q must inherit all of its syntactic and semantic features from the declarative structure.

The transformational relationship between (17a) and (17b), (18a) and (18b), and (19a) and (19b) can be exhibited as follows, where the (b) sentences represent a short question.

- (17) a. xaraja zaydun
 got out Zayd
 Zayd got out.
- b. ?a zaydun ?
 Q Zayd
 Zayd [+Nom]?
- (18) a. qatala ^camrun zaydan
 killed ^cAmr Zayd
^cAmr killed Zayd.
- b. ?a zaydan ?
 Q Zayd
 Zayd [Acc]?
- (19) a. marartu bi-zaydin
 passed I by Zayd
 I passed by Zayd.
- b. ?a bi-zaydin ?
 Q by Zayd
 By Zayd [+Gen]?

In examples (17b), (18b), and (19b), the constituent in the declarative structure can transform to a Yes-No-Q structure carrying all its syntactic and semantic features.

The Yes-No-Q has another syntactic constraint when adjoined to the negation structure. According to this constraint, the (T-Neg) transformational negation must apply first and then Yes-No-Q can apply. But the only question

particle which is used when Yes-No-Q applies is ?a. The change from basic to derived Yes-No-Q and T-Neg structure is shown by the following steps presented in (20).

- (20) a. Basic structure →
 b. Neg-structure →
 c. Yes-No-Q-structure →
 d. Yes-No-Q-Neg-Basic structure

The underlying structure of the four operations in (20) can be seen in the following examples.

- (21) a. $\left. \begin{array}{l} ?a \\ *hal \end{array} \right\}$ lam yaqum zaydun ?
 Q Neg stood up Zayd
 Did not Zayd stand up?

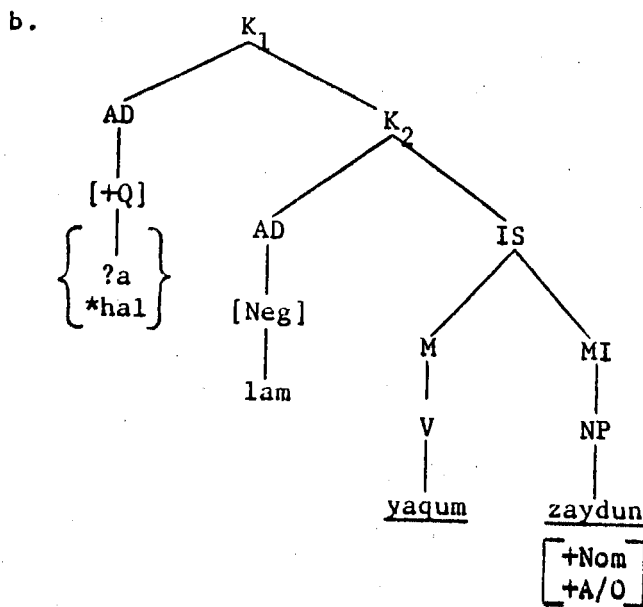

The generalized transformational rules of Yes-No-Q adjoined to an embedded structure, however, are similar to the previous transformational process of (20). Here, the

basic structure is generated first, the embedded structure will come second, and then the main structure and the embedded structure will be transformed to a Yes-No-Q. The constraint here is that the only transformational question particle which may be used is ?a. The transformational process of constructing a Yes-No-Q in the embedded structure is presented in (22).

- (22) a. Basic structure \longrightarrow
 b. Embedded structure \longrightarrow
 c. Yes-No-Q structure \longrightarrow
 d. Yes-No-Q Embedded Basic structure

The transformational operations of (22) can be seen in the following examples.

- (23) a. $\left. \begin{array}{l} ?a \\ *hal \end{array} \right\}$ zaydun ?in tadrib-hu ∅-Pro yadrib-ka ∅-Pro ?
 Q Zayd if hit him you hit you he
 Is it Zayd that if you hit him he will hit you?

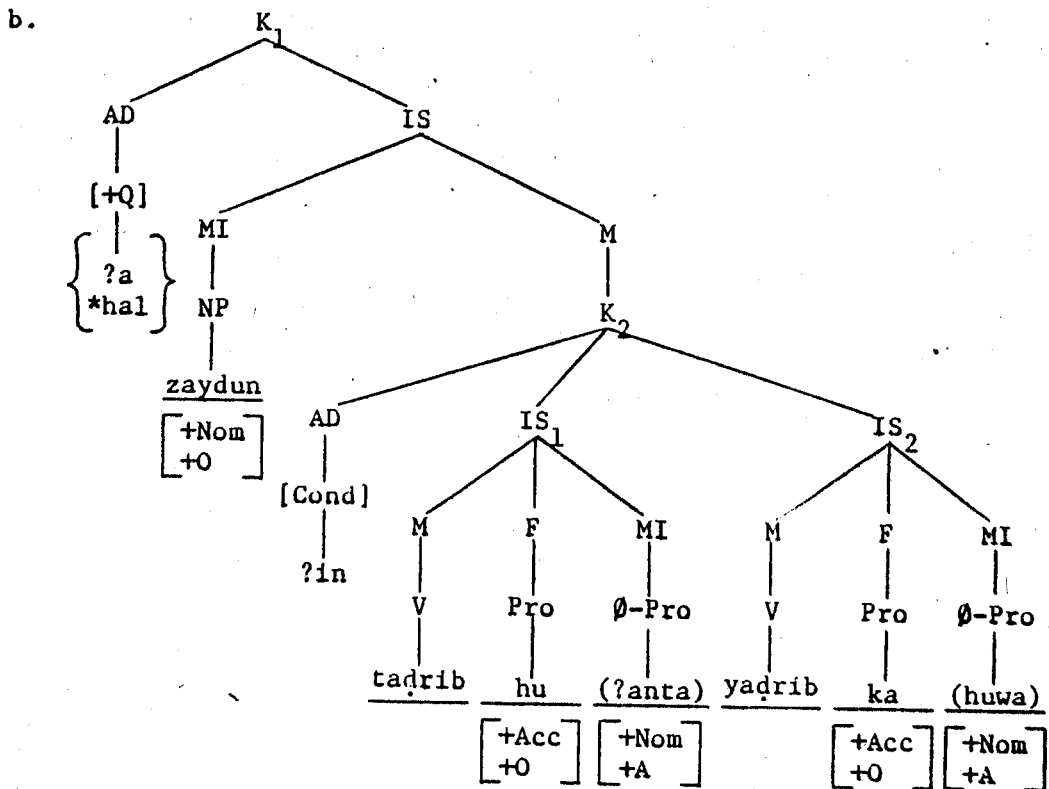

1.2. The Semantic Aspects of the Yes-No-Question

Applying the semantic system of ?Al-Jurjāni to the Yes-No-Q, we can see that the transformational question particle operates on the constituent adjacent to it on its right. At the same time, it operates on the whole structure. According to this system, the constituent adjacent to the question particle will be questioned. In addition, the whole structure will be affected semantically. The semantic system of the Yes-No-Q is exhibited in (24).

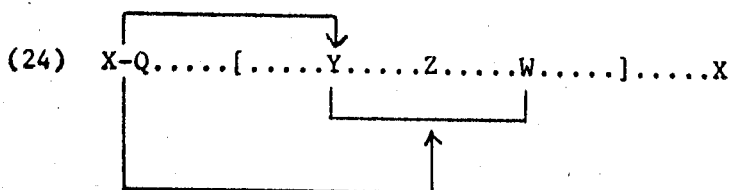

This means, if Y = MI(NP-agent), then we are asking about the actor of the event; if Y = F(NP-object), then we are asking about the object which is acted upon; and if Y = M(V), then we are asking about the event or action. In other words, we are questioning the item to the immediate right of the question particle. The general meaning, however, will change the sentence containing Y, Z, and W from its declarative status to interrogative status. To illustrate the semantic aspects of the Yes-No-Q, let us consider the following examples.

- (25) a. $\left\{ \begin{array}{l} ?a \\ hal \end{array} \right\}$ ja?a rajulun ?
 Q came man
 Did a man come?

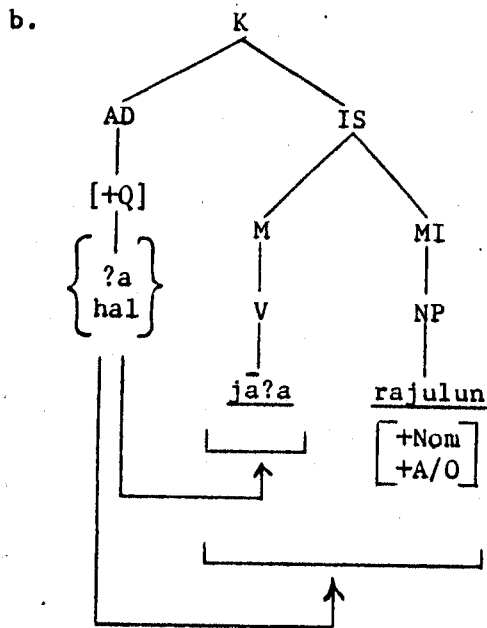

- (26) a. $\left. \begin{array}{c} ?a \\ \text{hal} \end{array} \right\}$ rajulun jā?a ∅-Pro ?
 Q man came he
 Was it a man who came?

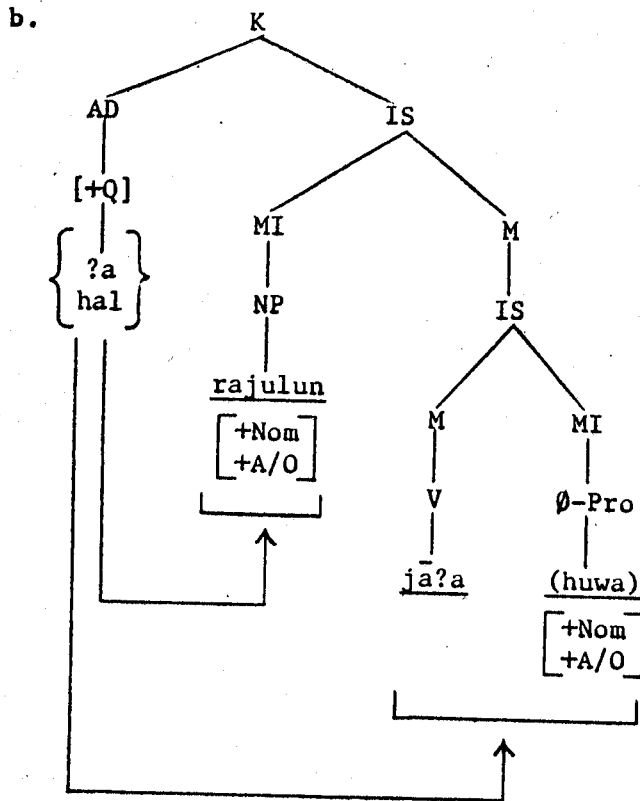

The clauses in (25b) and (26b) have different semantic structures. The structure in (25b) asks for specific information about the event of the verb and general information about the whole activity. On the other hand, the structure in (26b) asks about the kind of person who came, i.e., whether it is a man or a woman.

In short, the constituent most immediately adjacent to the question particle is assumed to bear on the specific

(28) Verbal Structure

a. man daraba zaydun ?

whom hit Zayd

Whom did Zayd hit?

b.

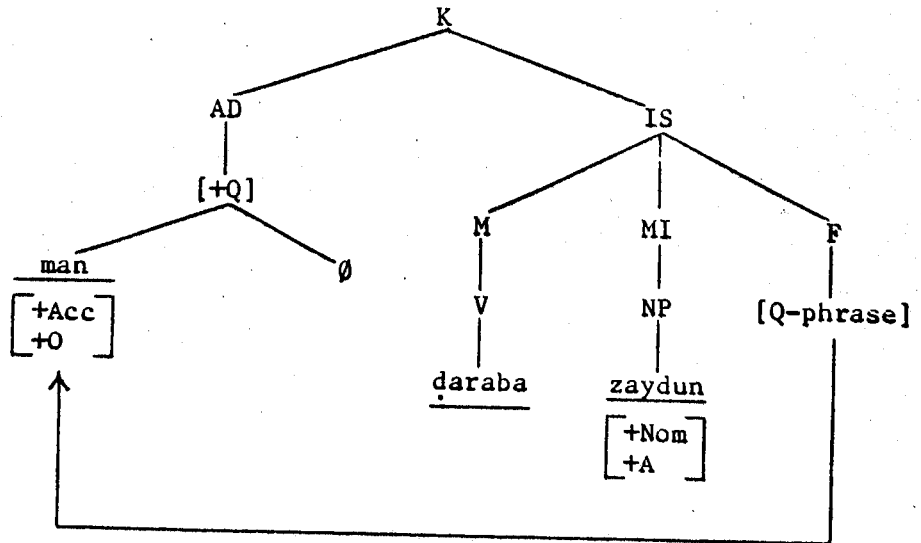

(29) Equational Structure

a. ?ayna mayyun ?

where Mayy

Where is Mayy?

b.

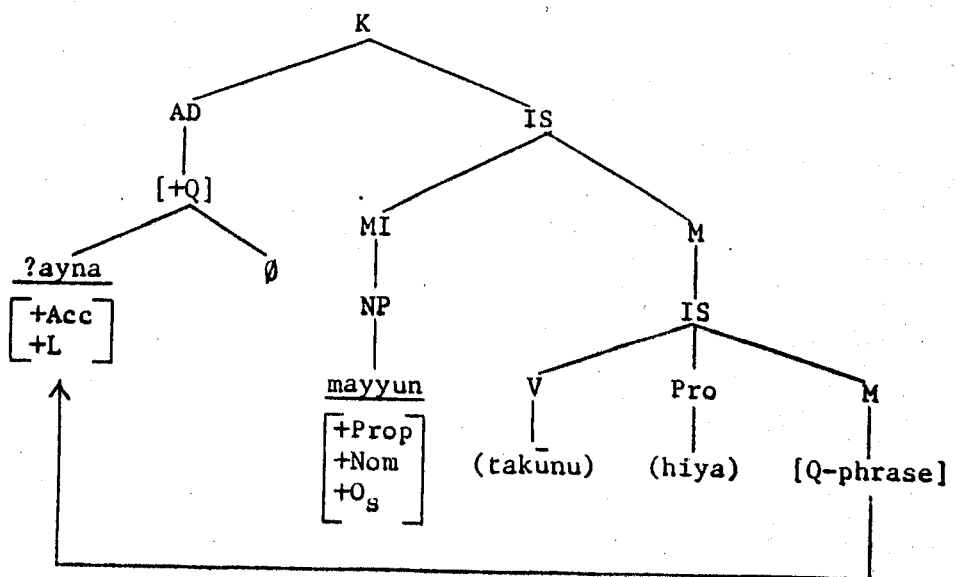

The Q-phrase which is associated with the MI-position, on the other hand, is the nominal structure. Here the Q-phrase is generated under the MI-node, therefore there will be no Q-movement. The Q-phrase here bears syntactic and semantic relations. This can be seen in configurations (30) and (31).

(30) Nominal Verbal Structure

- a. man ja?a ∅-Pro ?
 who came he
 Who came?

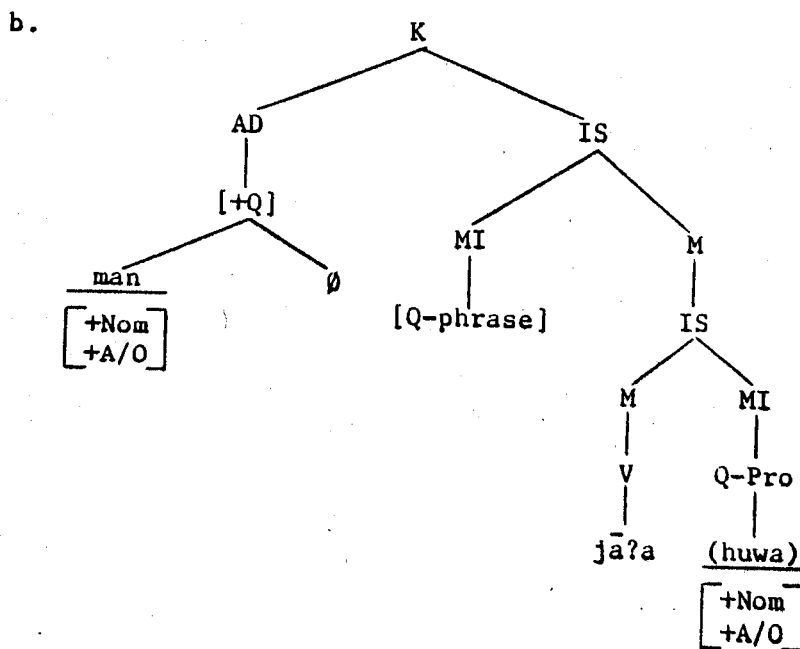

(31) Nominal Equational Structure

- a. man fī ħimṣa ?
 who in Homs
 Who is in Homs?

b.

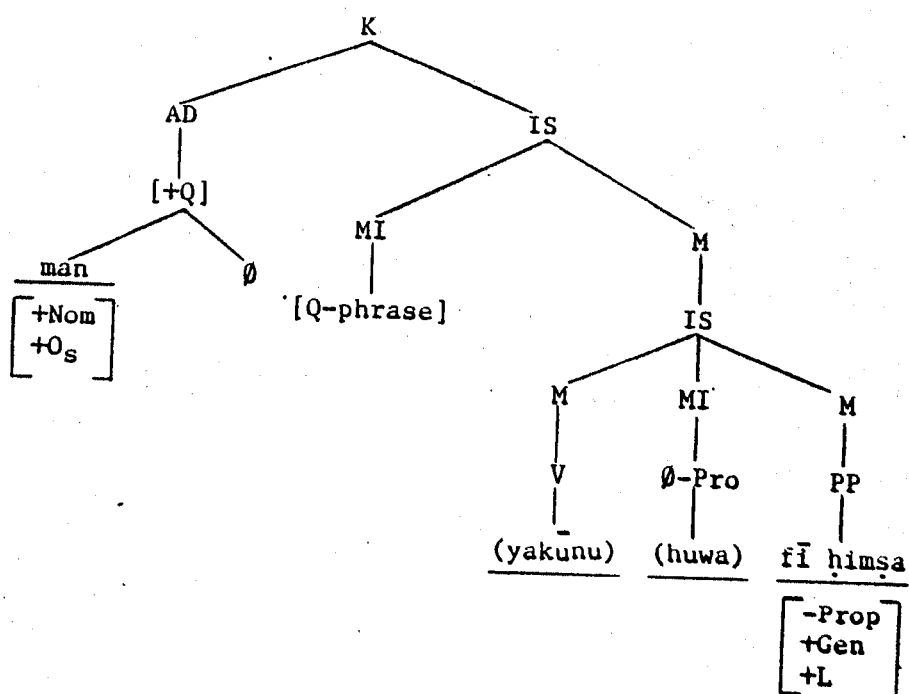

This means that the nominal verbal structures and some nominal equational structures (whose constituent adjacent to the Q-phrase is [-proper noun]) do not show any movement. In the non-movable Q-phrase in (30) and (31), the empty category of the covert pronoun MI(\emptyset -Pro), or damir mustatir, will be adjacent to the verb on its right in the case of nominal verbal structure, while the Q-phrase is located under the MI-node.

2.1. Q-Movement in the Verbal Structures

The Arabic verbal structures suggest that the Q-movement has just one direct movement starting from the F-node to the +Q-node, i.e., from the IS-node to the K-node. The justification for such a direct movement is that each particle in Arabic has its peculiar syntactic and semantic

properties. Thus the Q-phrases are different from the complementizers, even though all these particles are subsumed under the AD-node. Let us consider the following examples.

(32) a. ?arāda zaydun ?an yuqābila ∅-Pro } (a) mayyan
(b) ḥazīnan
(c) ?al-yawma
(d) fī ṣ-ṣīni

wanted Zayd Comp meet he

Zayd wanted to meet } (a) Mayy
(b) sadly
(c) today
(d) in China

b. man ?arāda zaydun ?an yuqābila ∅-Pro (a) ?

whom want Zayd Comp meet he

Whom did Zayd want to meet?

c. kayfa ?arāda zaydun ?an yuqābila ∅-Pro mayyan (b) ?

how want Zayd Comp meet he Mayy

How did Zayd want to meet Mayy?

d. mata ?arāda zaydun ?an yuqābila ∅-Pro mayyan (c) ?

when want Zayd Comp meet he Mayy

When did Zayd want to meet Mayy?

e. ?ayna ?arāda zaydun ?an yuqābila ∅-Pro mayyan (d) ?

where want Zayd Comp meet he Mayy

Where did Zayd want to meet Mayy?

In (32a), the Q-phrase is generated at the end of the structure under the F-node. The underlying structure of the clause (32a) is presented in (33).

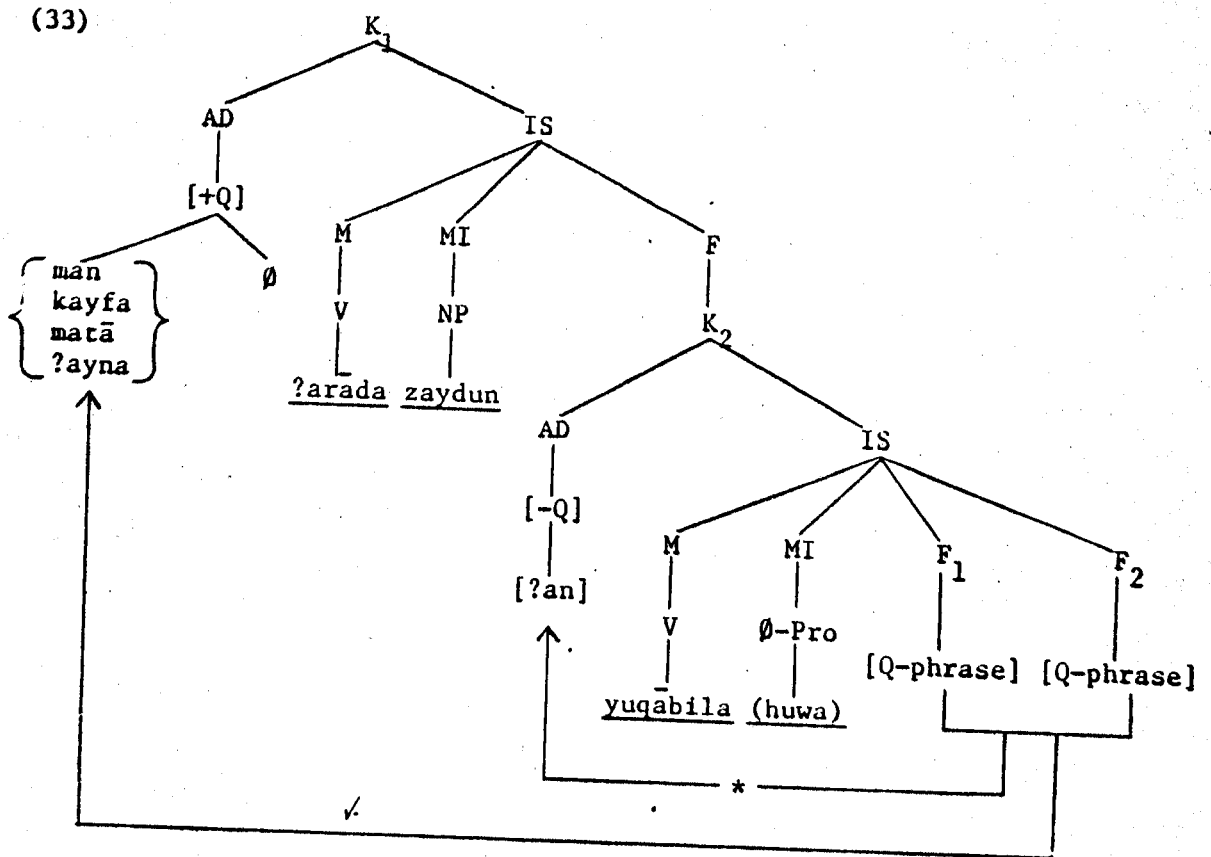

As indicated in (33), the Q-phrase which might be (a) F(NP-object), (b) F-(NP-manner), (c) F(AdvP-time), or (d) F(AdvP-location) can move directly from the end of the clause to the initial position, i.e., +Q-node.

2.2. Q-Movement in the Nominal Verbal Structures

As proposed before, the Q-phrase in the nominal verbal structure is generated under the MI-node (i.e., if the Q-phrase is MI) without need of Q-movement. Arabic, however, exhibits some structures which consist of MI(NP) as a theme and an I-Q structure as a rheme or comment. This means that the Q-phrase of the sentential comment is moved to the

+Q-position from the position where it is generated, i.e., F-node. Let us consider the following examples.

- (34) a. zaydun ?ayna daraba-hu ^camrun ?
 Zayd where hit him ^cAmr
 As for Zayd, where did ^cAmr hit him?

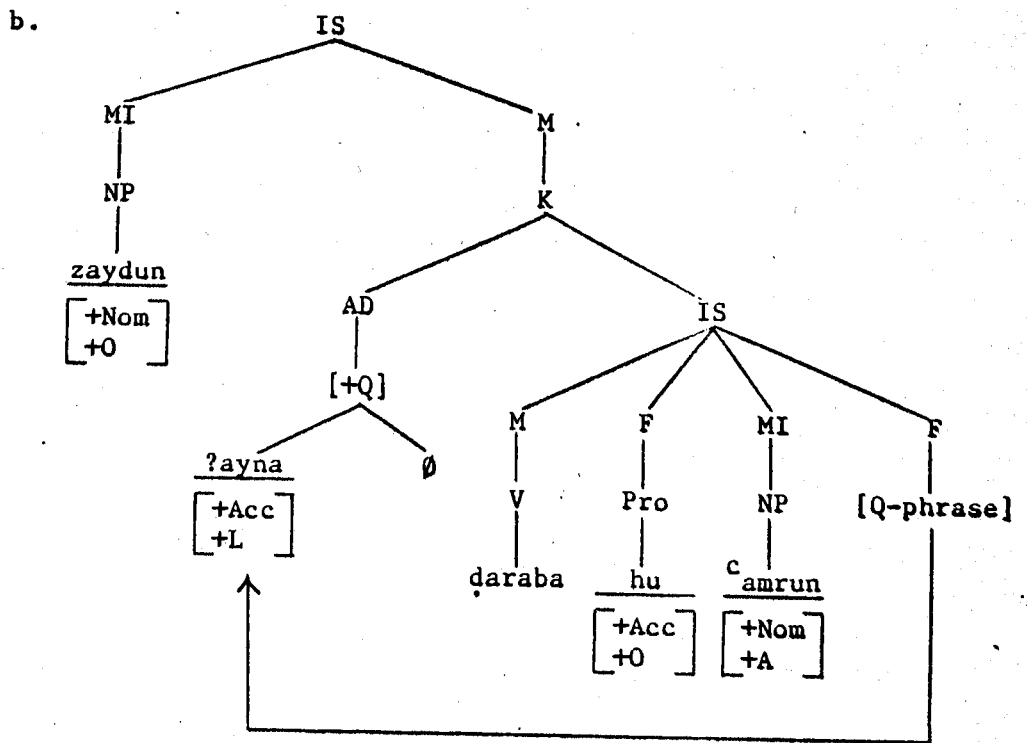

- (35) a. mayyun kayfa qābala-hā zaydun ?
 Mayy how met her Zayd
 As for Mayy, how did Zayd meet her?

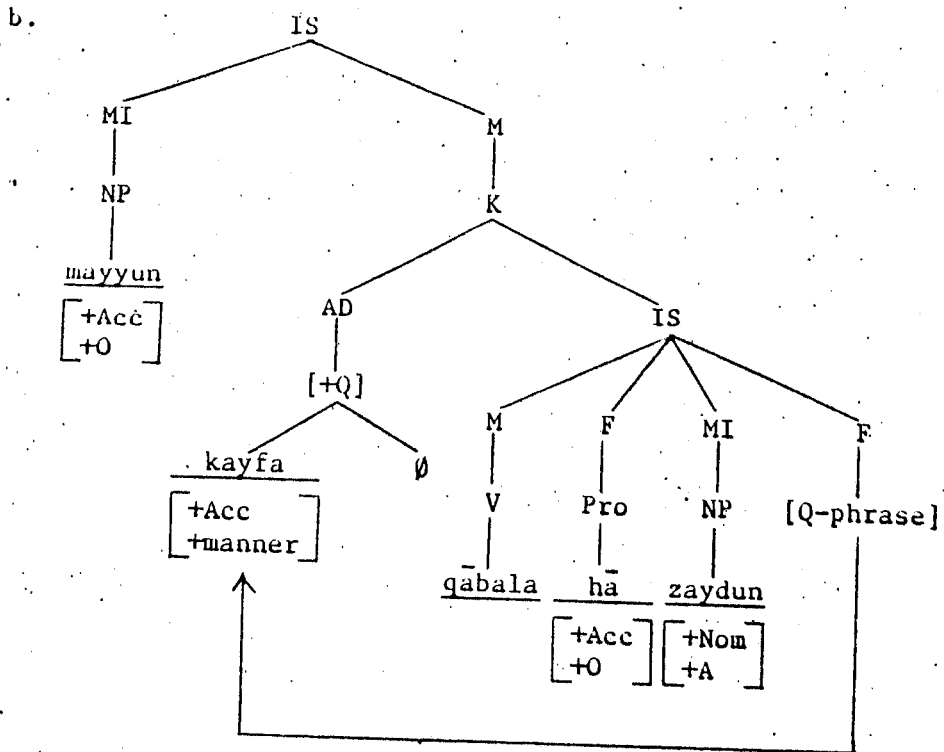

In (34b) and (35b) the pronominal copy associated with the question sentential comment is coreferential with the antecedent MI(NP-topic). At the same time, movement rule operates freely in the sentential comment, moving the Q-phrase from the end of the clause to the +Q-position which is adjacent to the right of MI(NP-topic).

This structural relation is possible also in another type of nominal verbal structure, especially when the sentential comment of the question is dominated by the MI(Q-phrase) which is generated in the base without involving any transformation rule. The constraint here is that the MI(NP-object) must precede the MI(Q-phrase); at the same time, the MI(NP-object) must be coreferential with a

resumptive pronoun in the sentential comment (i.e., the covert subject pronoun). The other constraint is that the MI(Q-phrase) must be coreferential with a resumptive pronoun attached to the verb in the sentential comment. This relation can be seen from the following examples.

- (36) a. mayyun man ?aḥabba-hā ∅-Pro ?
 Mayy who loved her he
 As. for Mayy, who loved her?

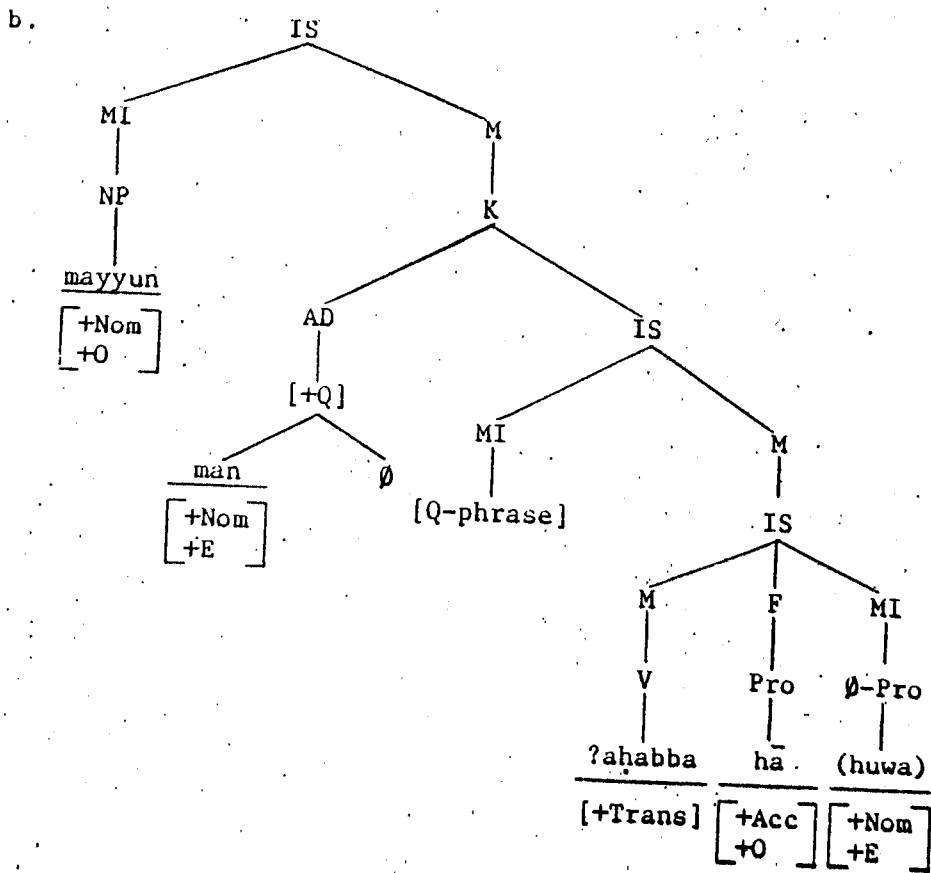

Arabic exhibits a third type of nominal verbal structure when the MI(Q-phrase) alone is generated in the base. Here there must be a resumptive pronoun in the

sentential comment. The condition here is that the resumptive pronoun, which can be overt or covert, must meet the conditions of (37).

- (37) a. It must be coreferential with its antecedent MI(Q-phrase).
- b. The resumptive pronoun and its antecedent must agree in gender, number, and person.

The relations between the MI(Q-phrase) and the resumptive pronoun can be seen in the following examples.

- (38) a. ?ayyuhum jā?a ∅-Pro ?
 which of them came he
 Which of them came?

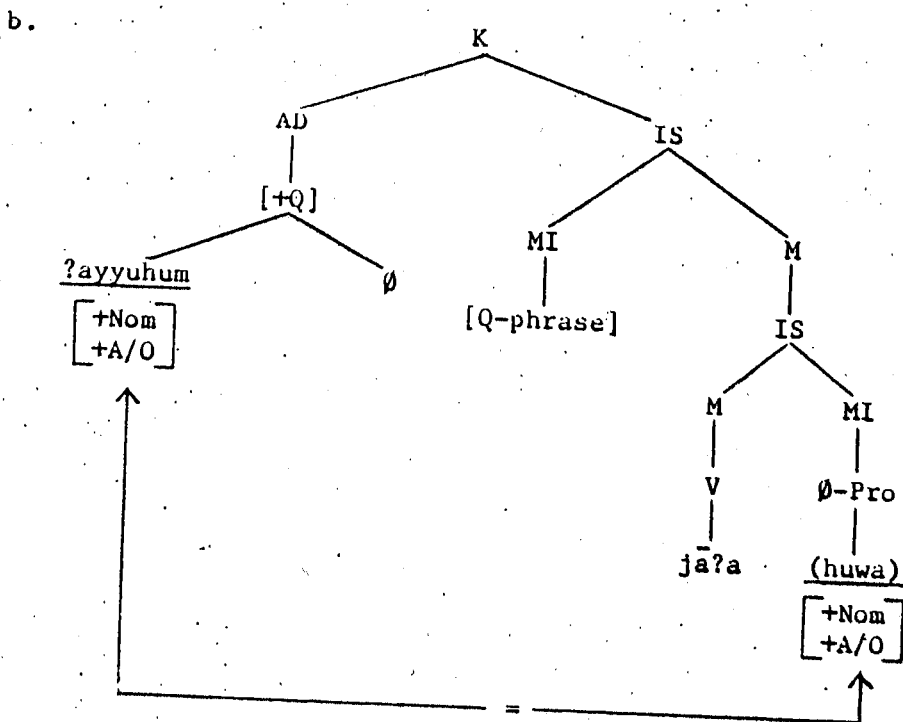

- (39) a. ?ayyuhum ḍaraba-hu zaydun ?
 which of them hit him Zayd
 Which of them did Zayd hit?

b.

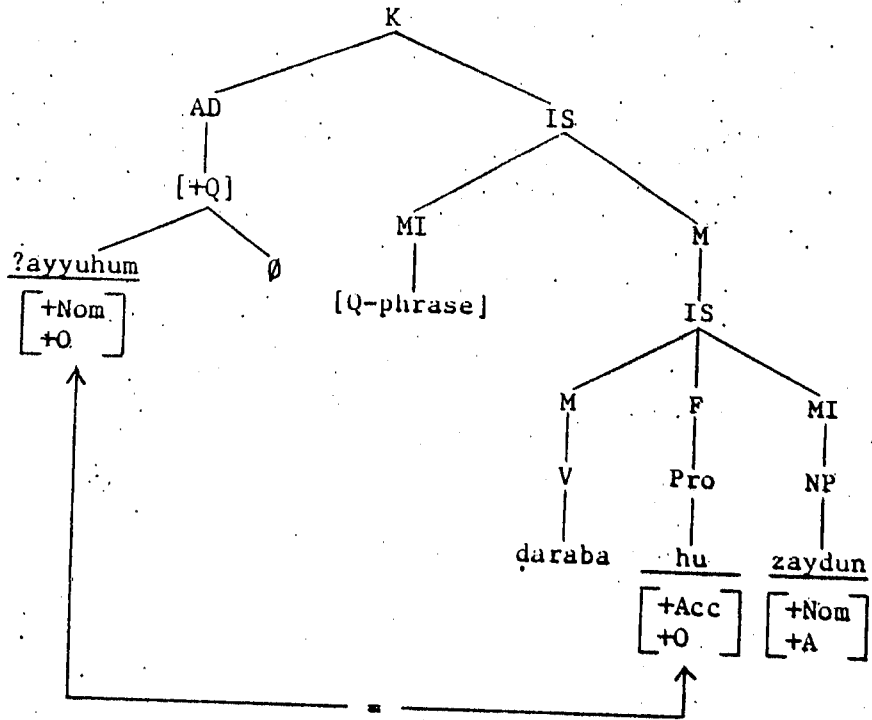

- (40) a. ayyuhum marra zaydun bi-hi ?
 which of them passed Zayd by him
 By which of them did Zayd pass?

b.

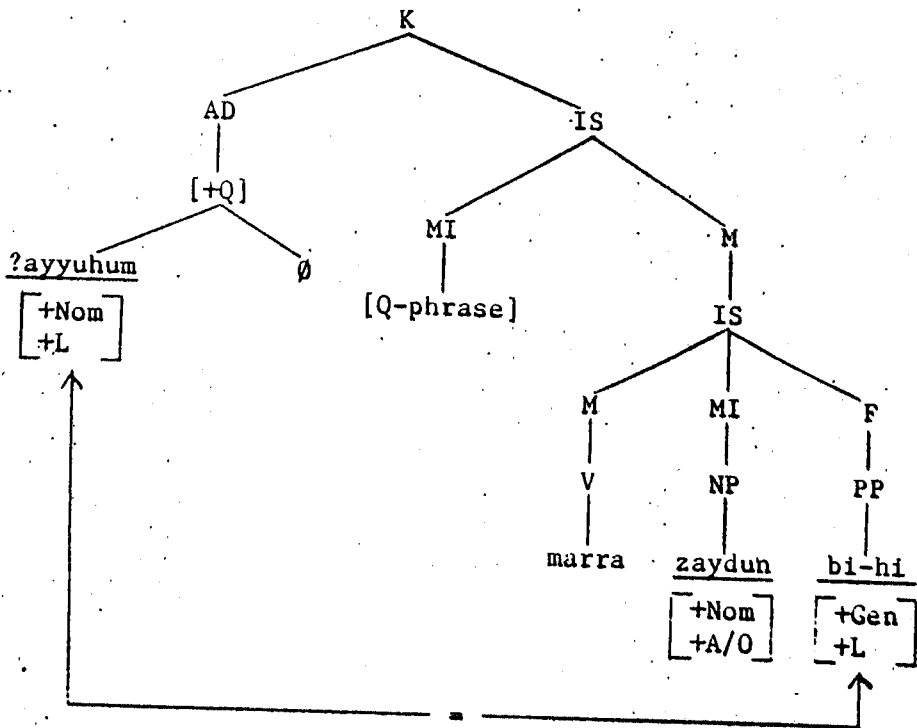

In (38b), the MI(Q-phrase), i.e., ?ayyuhum, is coreferential with the resumptive covert pronoun (\emptyset -Pro) which is in a subject position. The MI(Q-phrase) in (39b) is coreferential with the resumptive overt pronoun hu, which is in an object position. The MI(Q-phrase) in (40b) is coreferential with the resumptive overt pronoun hi, which is in an object-of-preposition position.

2.3. Q-Movement in the Nominal Equational Structures

The equational structure in Arabic shows two types of Q-phrases. One Q-phrase is generated under the M-node, and it is moved from its position to the +Q-node under certain constraints. This type of Q-phrase must be adjacent to a proper noun. The second Q-phrase is generated under the MI-node directly, and there is no Q-movement involved here. This type of Q-phrase must be adjacent to a non-proper noun. Let us consider the following examples.

(41) a. zaydun ?al-muntaliqu
 Zayd the departer
 Zayd is the departer.

b. man il-muntaliqu ?
 who the departer
 Who is the departer?

c.

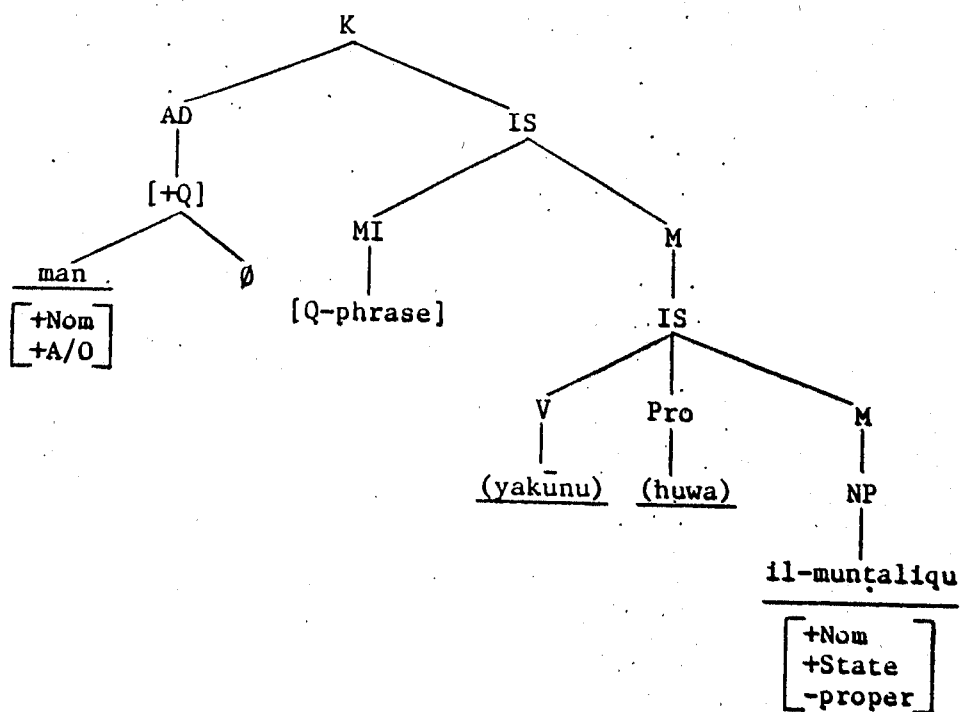

In (41c), the Q-phrase is generated in the base under the MI-node. On the other hand, some equational structures show that the Q-phrase, after it is generated in the base under the M-node, will be moved to the +Q-node. The constraints here are that the Q-phrase which is moved must either represent the adverb of location, time, or manner, or must be adjacent to a proper noun such as Zayd. These constraints can be seen in the following examples.

(42) a. zaydun ṣā^{v-c}irun
 Zayd poet
 Zayd is a poet.

b. man zaydun ?
 who Zayd
 Who is Zayd?

c.

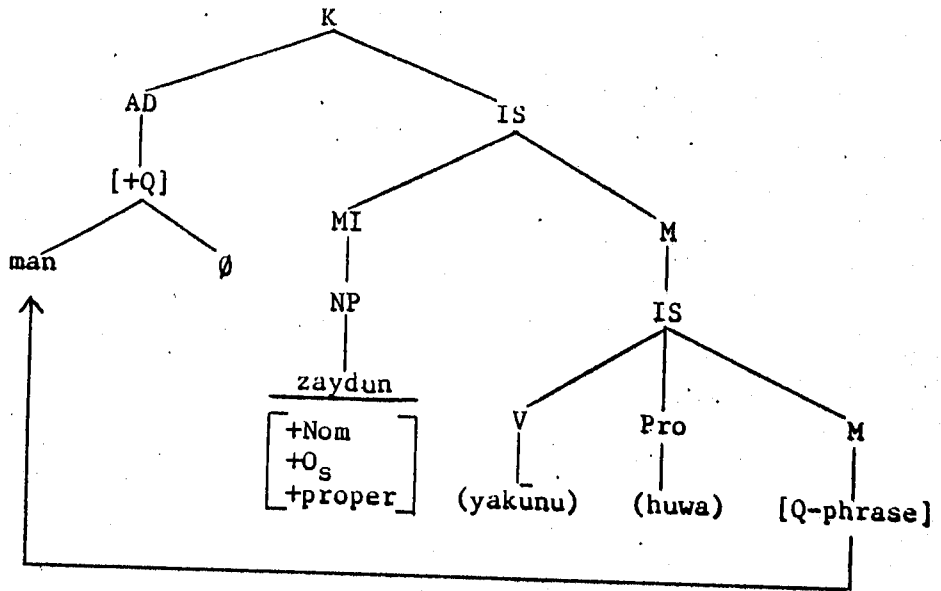

(43) a. ?al - qitālu l-yawma
 the fighting today
 The fighting is today.

b. matā l - qitālu ?
 when the fighting
 When is the fighting?

c.

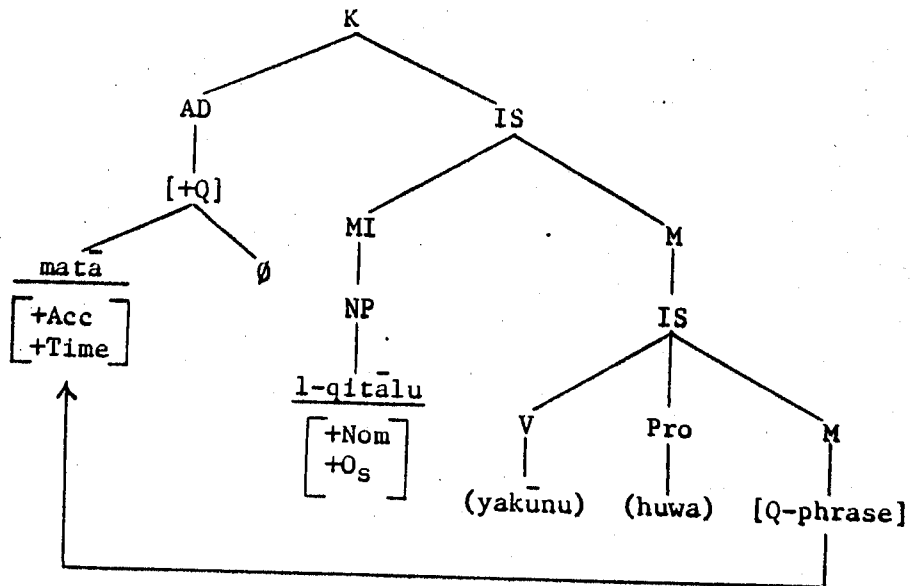

(44) a. mayyun fī ḥimṣa
 Mayy in Homs
 Mayy is in Homs.

b. ?ayna mayyun ?
 where Mayy
 Where is Mayy?

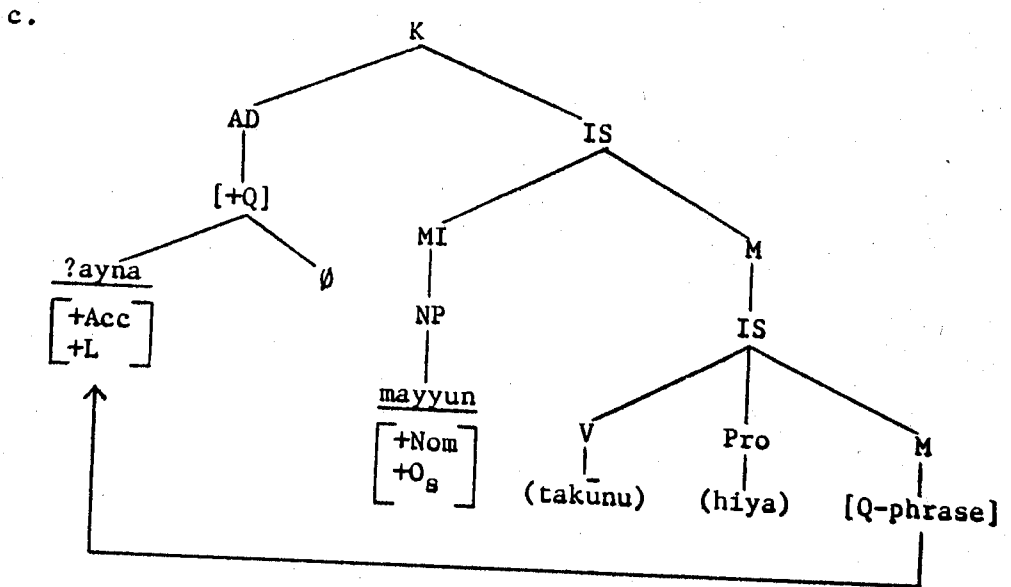

(45) a. mayyun jāmilatun wa ?alma^c iyyatun
 Mayy beautiful and smart
 Mayy is beautiful and smart.

b. kayfa mayyun ?
 how Mayy
 How is Mayy? .

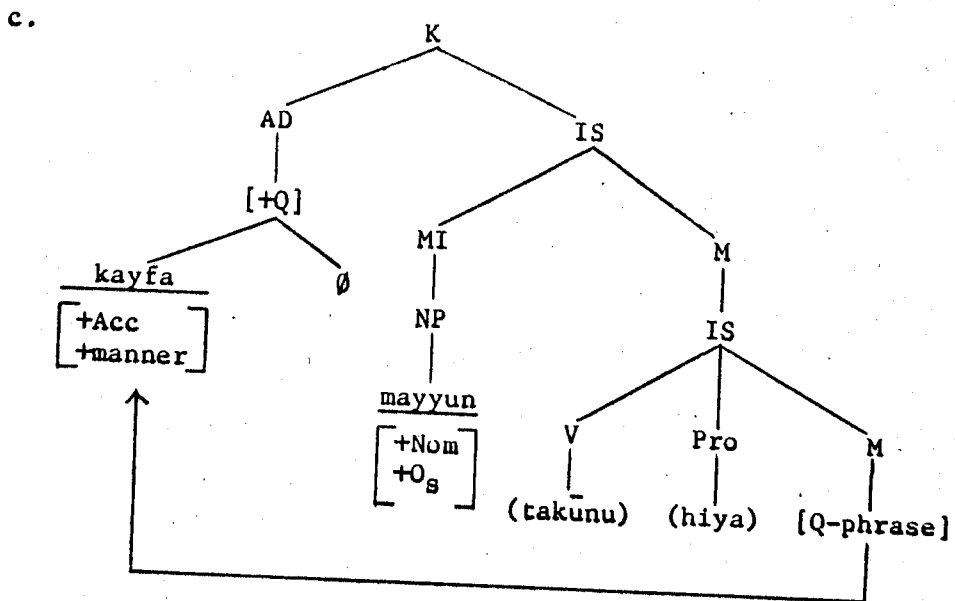

As seen in (42c), (43c), (44c), and (45c), the Q-phrase is generated at the end of the structure (M-node) and it is moved to the +Q-node.

2.4. The Syntactic and Semantic Constraints of the Information Question

In this section, we will see that there are certain syntactic and semantic restrictions which block the Q-element from moving freely in the sentential structures. The restrictions which are imposed on the Q-element, however, can be discussed under two general constraints. The first constraint is related to an independent Q-phrase. The second constraint is related to a unified Q-phrase.

2.4.1. Constraints on Independent Q-Phrases

Arabic sentential structures show that no two movements of Q-phrase and F(NP-object) can occur in a particular structure. The situation here is that the F(NP-object) moves to

the left of its verb to be sister-adjoined to it under the IS-node. At the same time, the Q-phrase in the same IS-node will move to a higher node (i.e., +Q-node). The constraint on the Q-phrase and F(NP-object) can be seen from the following examples.

- (46) a. $\frac{c}{\text{asiqa}} \frac{v}{\text{qaysun}} \frac{\text{laylā}}{\text{Laylā}}$
 loved Qays Laylā
 Qays loved Laylā.
- b. $\frac{\text{laylā}}{\text{Laylā}} \frac{c}{\text{asiqa}} \frac{v}{\text{qaysun}}$
 Laylā loved Qays
 It is Laylā that Qays loved.
- c. $\frac{\text{mata}}{\text{when}} \frac{c}{\text{asiqa}} \frac{v}{\text{qaysun}} \frac{\text{laylā}}{\text{Laylā}} ?$
 when loved Qays Laylā
 When did Qays love Laylā?
- d* $\frac{\text{mata}}{\text{when}} \frac{\text{laylā}}{\text{Laylā}} \frac{c}{\text{asiqa}} \frac{v}{\text{qaysun}}$,
 when Laylā loved Qays

As seen in (46b) and (46c), when one constituent movement occurs in the structure, it will be grammatical regardless of the nature of the constituent moved. But when two constituents are moved, as in (46d), the structure is ungrammatical. The transformational movement is exhibited in the configurations (47a), (47b), and (47c).

(47) a.

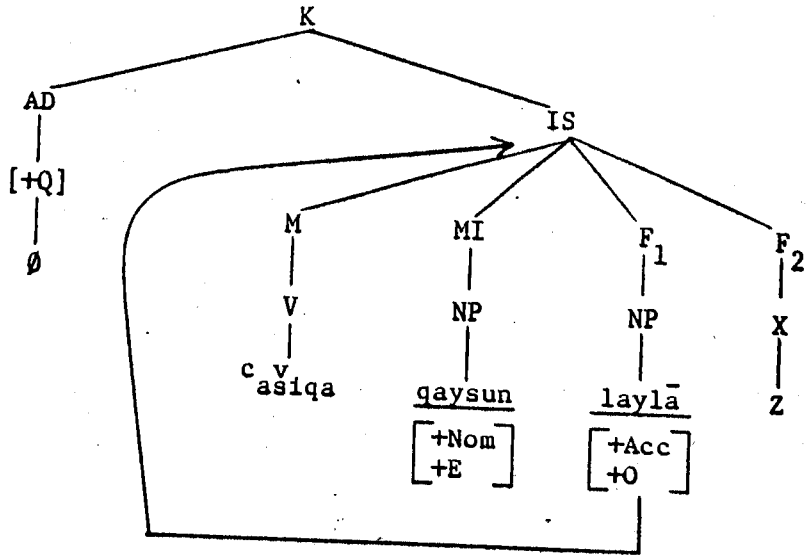

b.

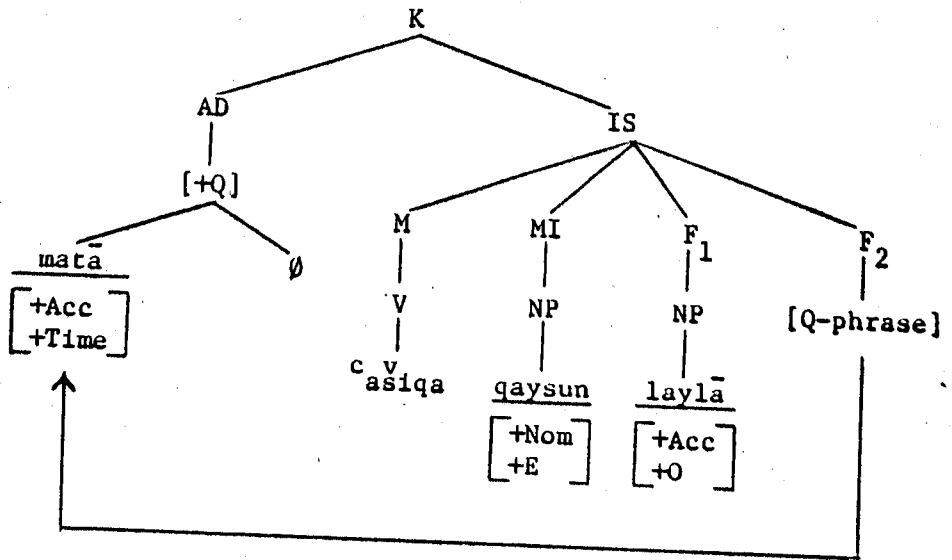

c.

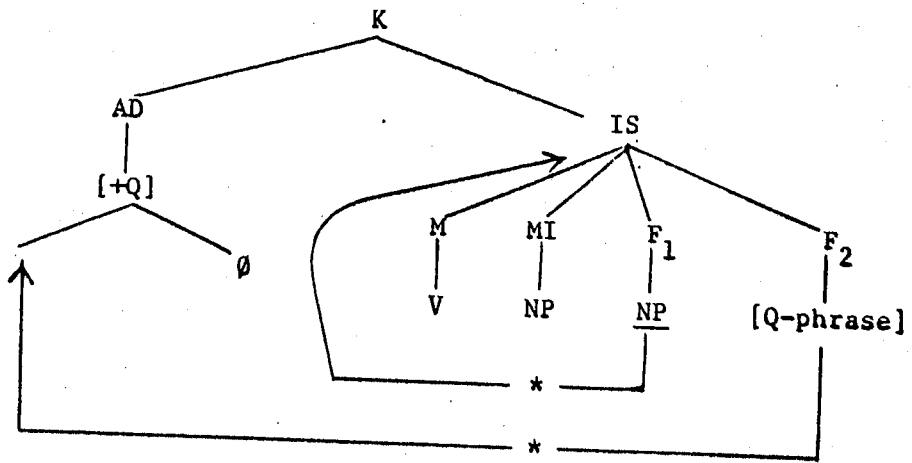

(50)

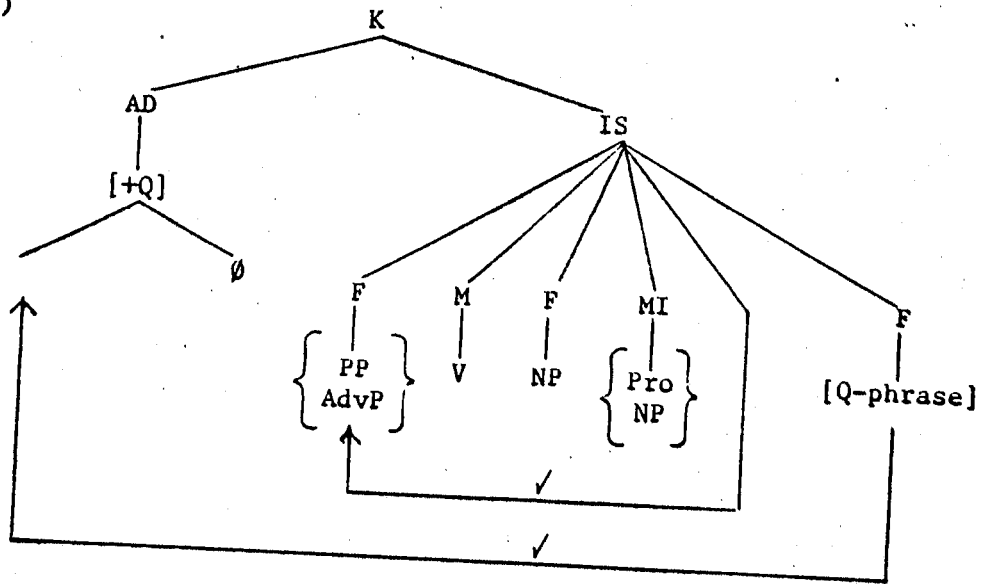

Examples (48) and (50) can be explained by one constraint such as (51).

- (51) Y cannot be adjacent to the left of M(V) and to the right of AD(+Q) at the same time unless Y is PP or AdvP or Q-phrase.

Related to this structure, some words in Arabic are marked either as accusative or genitive case. But when the PP or AdvP constituent moves from the end of the structure to the right of the Q-phrase, these words will be marked the case marker of accusative, i.e., [+Acc]. There is one Q-phrase which has the peculiarity of having an F(NP-TamyIz) word adjacent to it on its right. This Q-phrase is kam, i.e., how $\left\{ \begin{array}{l} \text{many} \\ \text{much} \end{array} \right\}$. The F(NP-TamyIz) in this case can be marked either [+Acc] or [+Gen], but when the PP or AdvP constituent is adjacent to the Q-phrase, the F(NP-TamyIz) will be marked [+Acc], as shown in the following examples.

- (52) a. bi - kam dirhamin
dirhaman ?i^vstarayta-hu ∅-Pro ?
 for how many dirham bought it you
 For how many dirhams did you buy it?

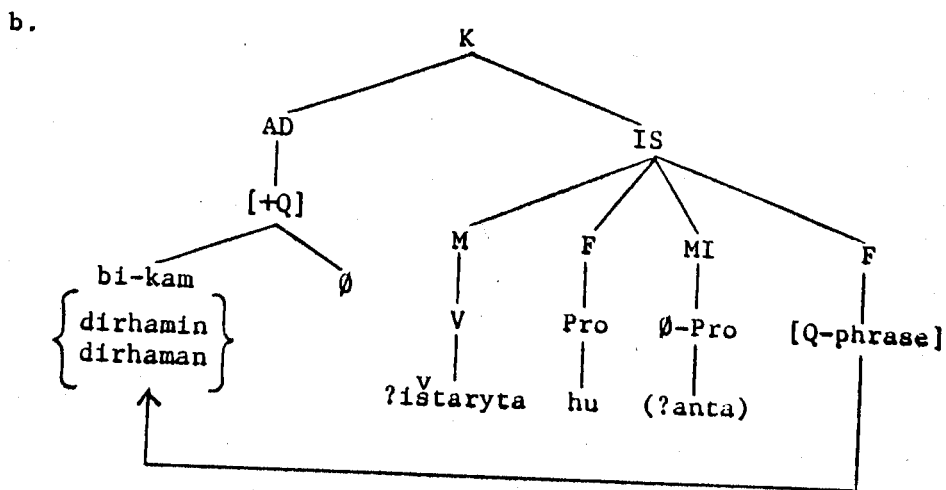

- (53) a. bi - kam AdvP-Time
?al-yawma *dirhamin
dirhaman ?i^vstarayta-hu ∅-Pro ?
 for how many today dirham bought it you
 For how many dirhams did you buy it today?

- b. kam AdvP-Location
fī l-bayti *waladin
waladan yal^cabu ∅-Pro ?
 how many in the house boy play he
 How many boys are playing in the house?

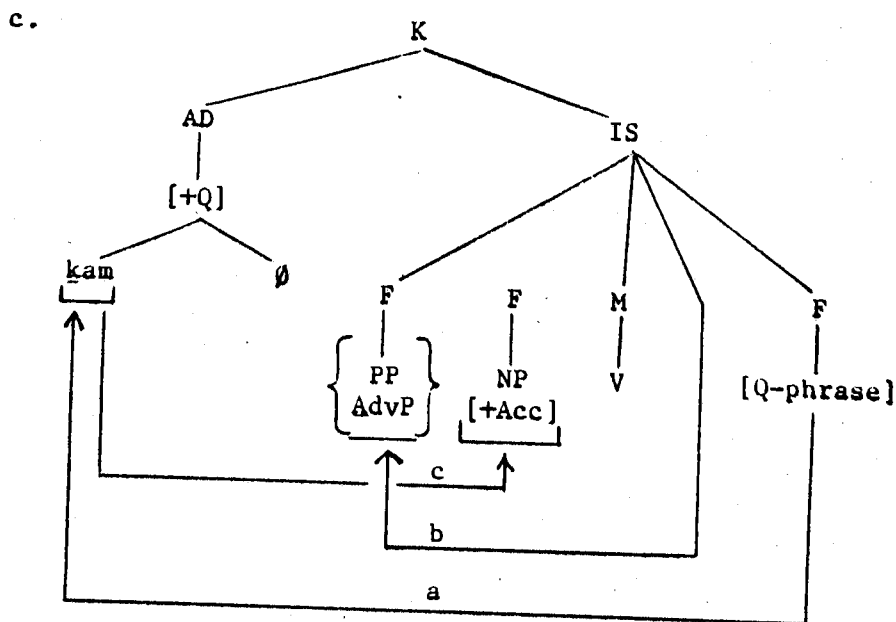

As seen in (52b), the word adjacent to the Q-phrase kam can be marked either [+Acc] or [+Gen]. But when the F(PP or AdvP) categories move to the right of the Q-phrase, the word F(NP) is marked only [+Acc]. We notice that (53c) undergoes three syntactic operations: (a) the major category of the Q-phrase and constituent adjacent to it is moved from the end of the structure to the Q-position; (b) the category of F(AdvP or PP) is moved from its original position to the right of the Q-phrase; and (c) the F(NP-Tamyiz) which is adjacent to the Q-phrase is moved to the right of F(PP or AdvP).

When operating in an embedded structure, the Q-movement will be of a different nature. Arabic structures show that when the Q-phrase is generated in an embedded clause, the Q-movement must move the Q-phrase to the nearest AD(+Q) to

its left position, otherwise the structure will be ungrammatical. The ungrammaticality comes from the fact that if we move the Q-phrase further it will belong to the main clause and it will no longer be in its embedded structural domain. This can be seen in the following examples.

- (54) a. qad ^cariftu ?ayyahum darabta ∅-Pro
 have just known which of them hit you
 I have just known whom you hit.

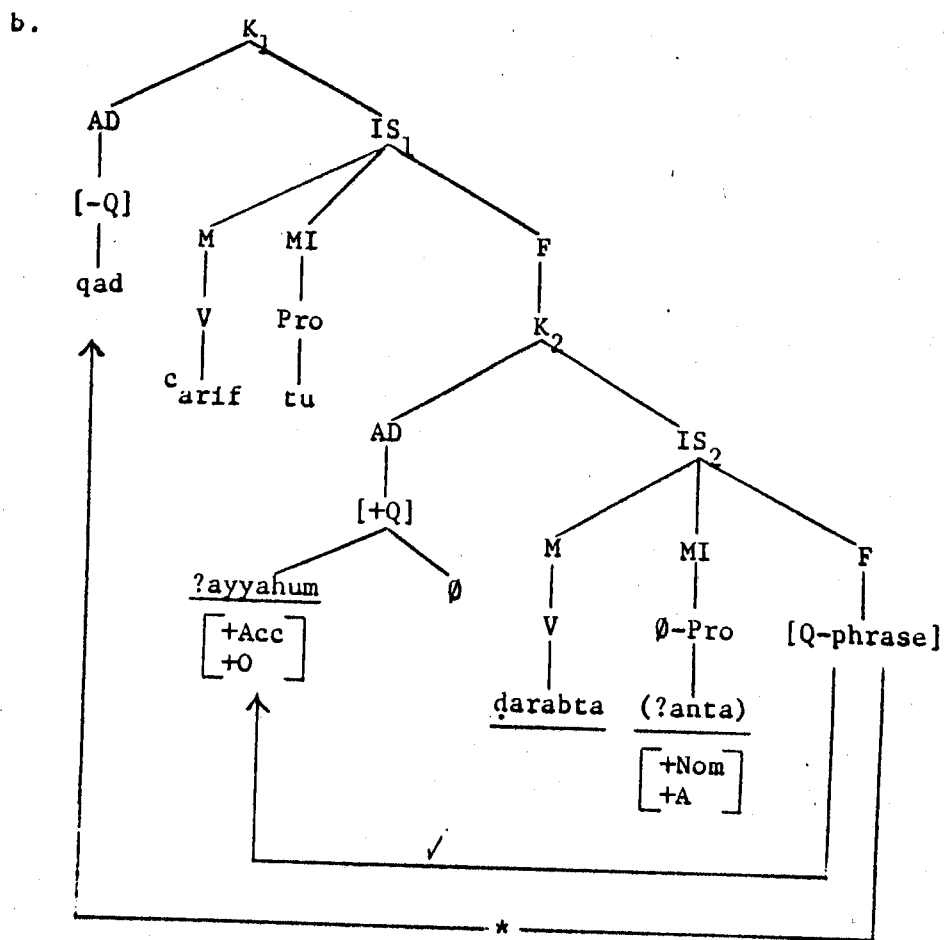

(55) a. qad ^cariftu bi - ?ayyihim mararta \emptyset -Pro
 have just known by which of them passed you
 I have just known by whom you passed.

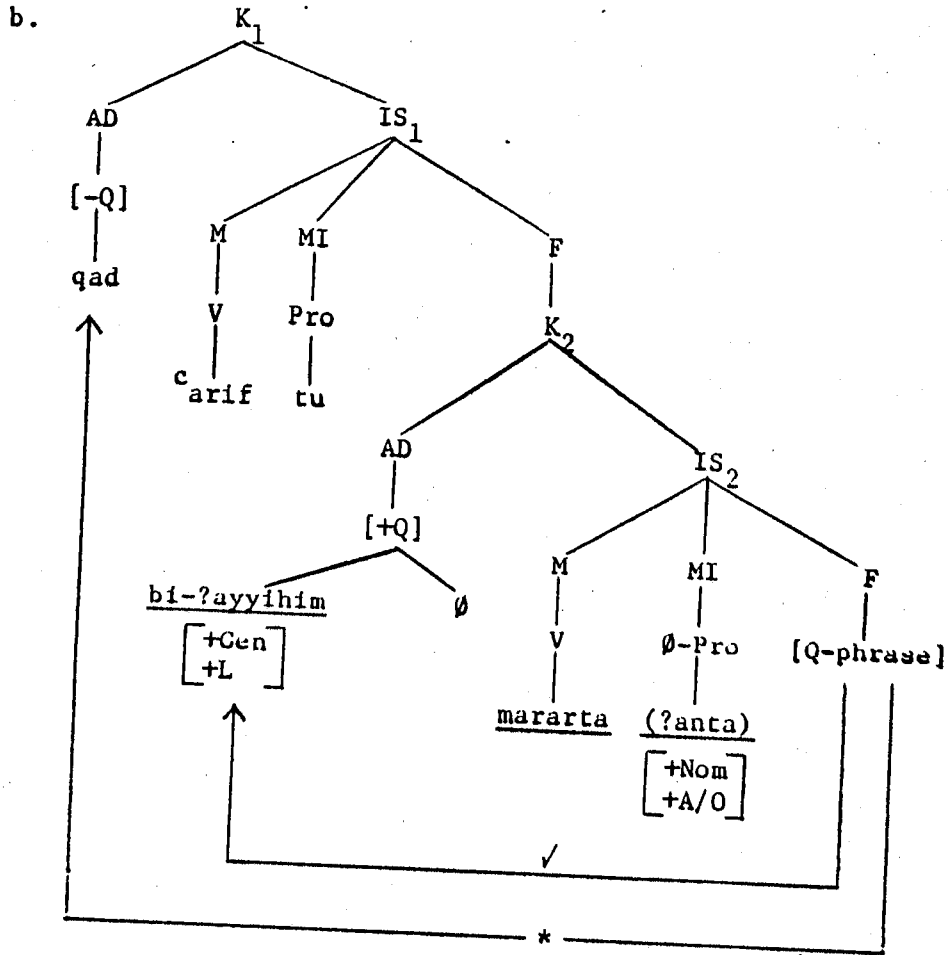

In (54b), the Q-phrase (object) ?ayyahum which is in the +Q position is dominated by the embedded structure IS₂. To construct a question formation, it moves from the end of the embedded clause (F-node) to the initial position (i.e., +Q-position). (55b) has the same process. Here the Q-phrase (object of preposition) bi-?ayyihim is in the +Q-position. It is generated at the end of the embedded

clause (F-node), thus being controlled by the embedded structure IS₂. The movement of these Q-phrases to the main clause will produce an ungrammatical structure.

In (54b) and (55b), the main clause IS₁ dominates the embedded clause IS₂, but not its constituents. Since the Q-phrase is a constituent within the domain of IS₂, it cannot be dominated by the main clause IS₁.

The constraint on Q-movement in (54b) and (55b) is similar in its process to another constraint even though they have different natures. In the new constraint, the Q-phrase cannot move from the position where it is generated to the initial position, i.e., the first AD(+Q). The reason is that the Q-phrase occurs in the nominal verbal structure, i.e., the Q-phrase cannot cross over the MI-node in the nominal verbal structure. Let us consider the following examples.

(56) a. zaydun ḍaraba ∅-Pro ^camran v- gāḍiban ?amsi
 Zayd hit he ^cAmr angrily yesterday

As for Zayd, he hit ^cAmr angrily yesterday.

b. zaydun { kayfa
matā } ḍaraba ∅-Pro ^camran ?
 Zayd how/when hit he ^cAmr

As for Zayd, { how
when } did he hit ^cAmr?

c.* { kayfa
matā } zaydun ḍaraba ∅-Pro ^camran
 how/when Zayd hit he ^cAmr

d.

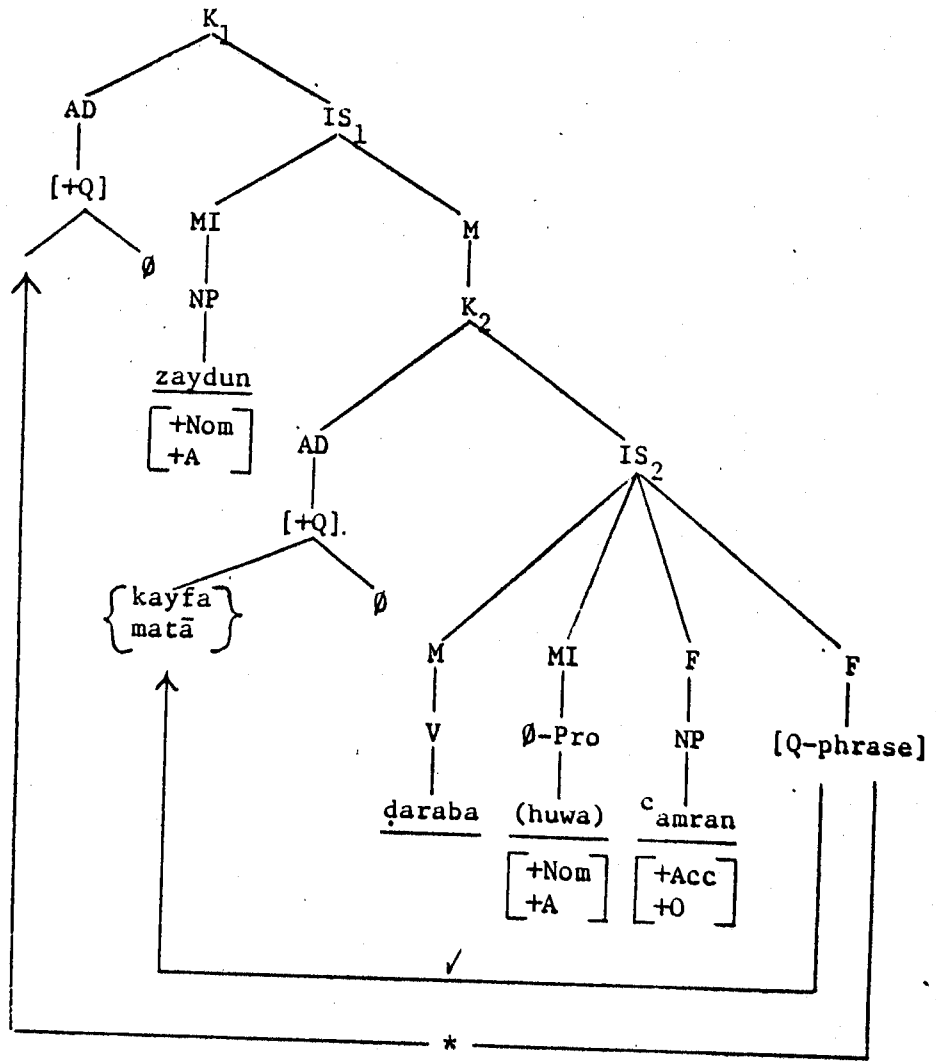

- (57) a. kayfa zaydun ṣāni^cun ∅-Pro ?
 how Zayd doing [VN] he
 How is Zayd doing?

. b.

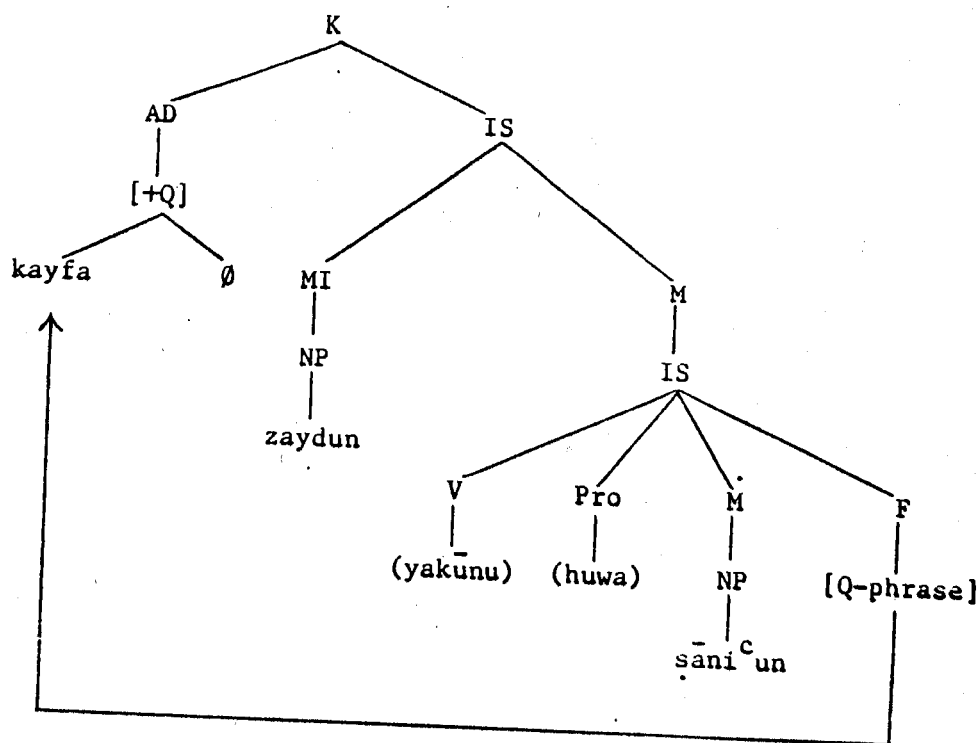

We notice in the nominal verbal structures of (56d) that the Q-phrase is moved from the end of the clause and crosses over the MI(NP) Zayd, but the result is an ungrammatical structure; whereas the movement to the AD(+Q) node which is adjacent to the right of the MI-node will result in a grammatical structure. The Q-phrase in the nominal equational structure of (57b) is moved from the end of the clause and crosses over the MI(NP) Zayd to reach the Q+ position, yet the structure is grammatical. The constraint which can capture the free Q-movement in the equational structure and the restrictive Q-movement in the nominal structure can be seen in (58).

- d. min ?ayna ?atā s-samaw?al ?
 from where came ?assamaw?al
 Where did ?assamaw?al come from?

The underlying structure of (59a-d) is in (59e).

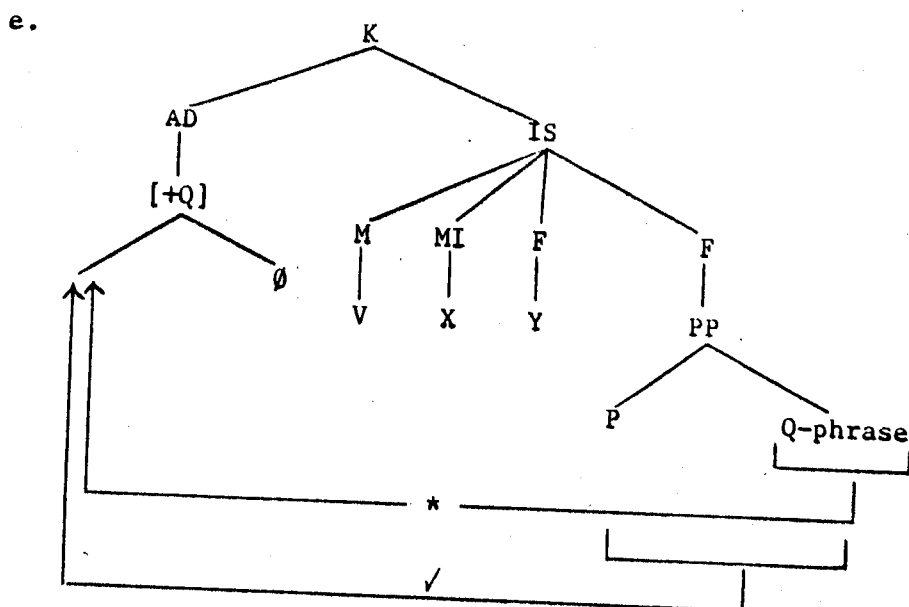

In (59e), the two lower categories of P and Q-phrase are controlled by a higher major category PP. Thus, when a transformational rule operates on the Q-phrase, it must move the whole PP category and not the Q-phrase alone; otherwise, the structure will be ungrammatical, as shown in (59e).

The other type of construction involving a major category dominating the Q-phrase and another constituent is the possessive construction. This can be exhibited in the following examples.

(60) a. ?ayya rajulin qābala zaydun ?
 which man met Zayd
 Which man did Zayd meet?

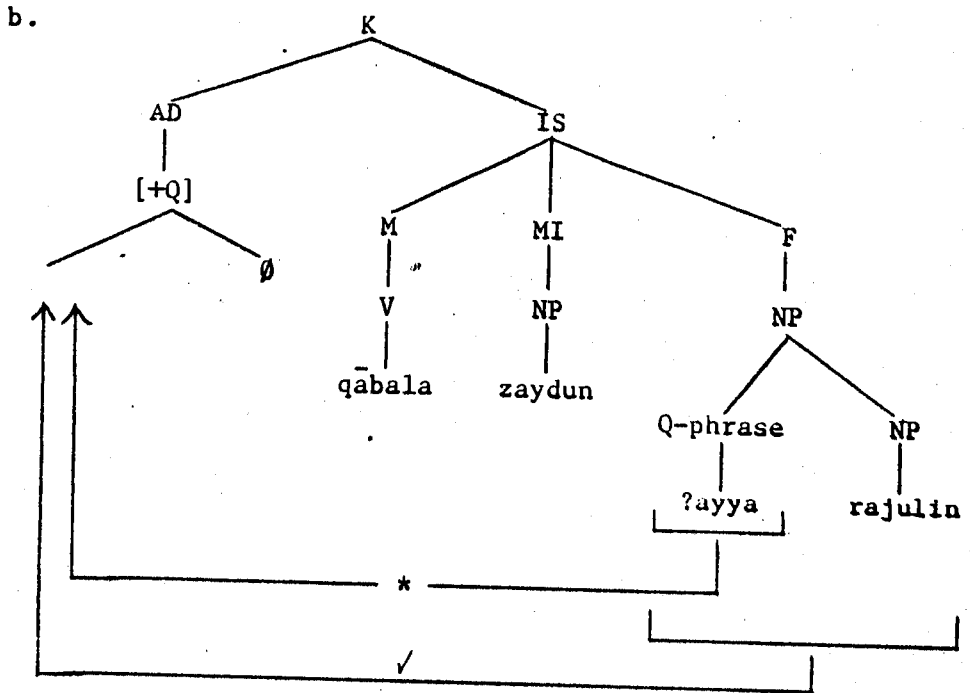

(61) a. ^{v-c}si'ra ?ayyi ^{v-c}sa'irin ?aḥabba zaydun ?
 poetry which poet liked Zayd
 Which poet's poetry did Zayd like?

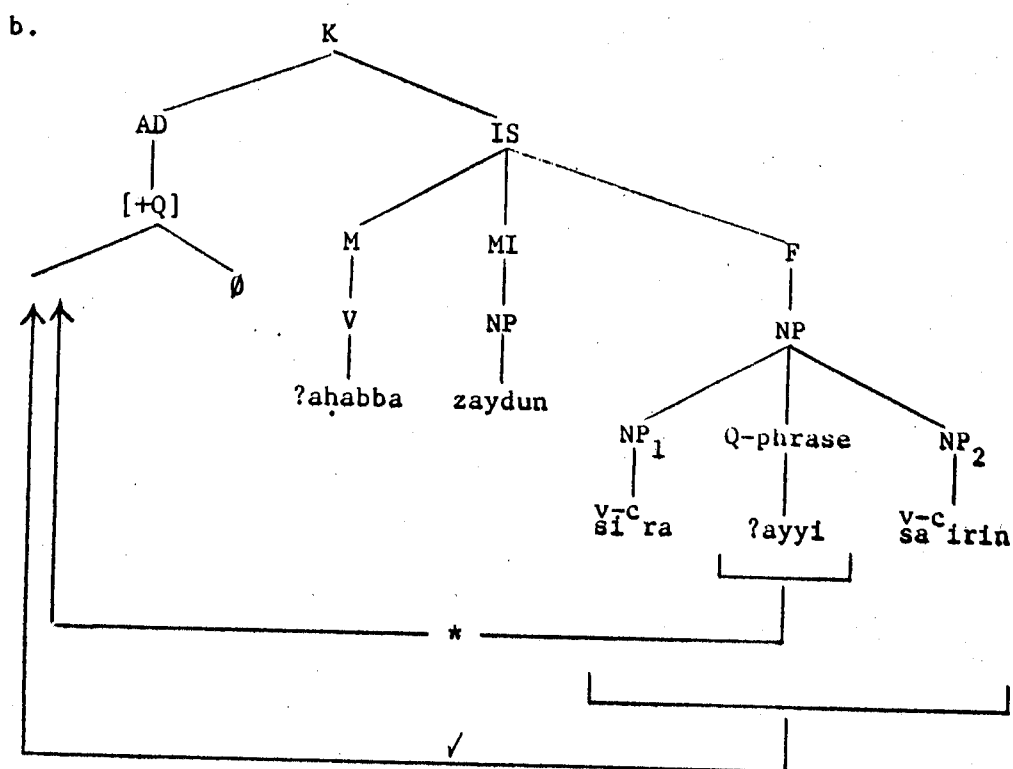

We notice that the Q-phrase is dominated by the F(NP) category in (60b) and (61b). The Q-movement is supposed to move the whole category of F(NP). I shall call the Q-phrase, in all these constraints Mobile Q-Phrase, i.e., the Q-phrase may precede the constituent, follow the constituent, or it may be between two constituents. These facts show that in Arabic when a category such as a prepositional phrase or possessive construction is involved, only the entire construction can be questioned, not a sub-part of the construction. This shows that prepositional phrases and possessives are 'islands' in Arabic.

In short, Arabic shows two question structures: (a) yes-no question, and (b) I-question. Syntactically, these two structures are subject to different transformations

which produce different meanings. Semantically, these two structures share the same semantic aspects, i.e., they generate specific and general meanings. The syntactic and semantic operations must be constrained in a certain structural environment in order to generate grammatical structures.

CHAPTER FIVE
THEORETICAL IMPLICATIONS

0. Introduction

Chomsky (1977:75) stated that "rules can vary from language to language within the constraints imposed by Universal Grammar, but it is often assumed that conditions on rules must be invariant. This assumption is somewhat arbitrary. There is no a priori reason not to assume the opposite."

In this chapter, I shall explain the theoretical implications for Arabic and Universal Grammar. Theoretically speaking, this chapter will show the principles of the sentence structure in Arabic, which can be subsumed under the Universal Grammar. In addition, it will show the specific principles of the Arabic sentence structure which is subsumed under the theory of Arabic grammar.

1. Arabic Sentential Theory

In Chapter One, we saw the general principles of the sentential theory of Arab grammarians through the analysis of the structures and their syntactic and semantic notions. This is important, however, for the general principles of linguistic theory and Universal Grammar because some of the Arabic structures might suggest some facts which can be important for developing the sentential theory in general.

been generated under the MI-node. In such a case, the verb must be either intransitive or transitive which must require an F(NP-object) to its right position. The general structure of the base-generated Q-phrase is shown in (26).

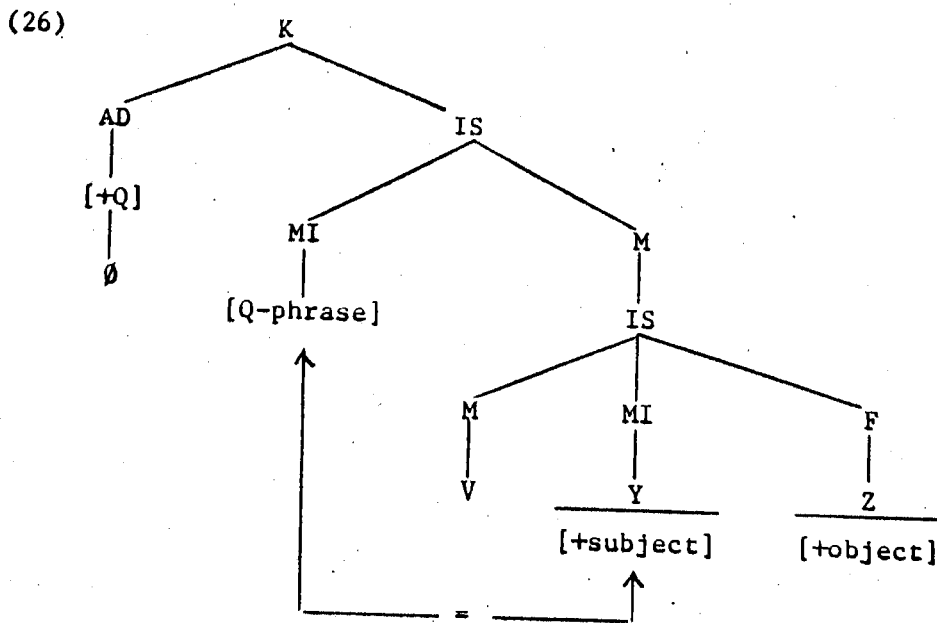

V = Intransitive or transitive whose NP-object is F(Z).
 Y = A full or an empty category of pronoun.

The coreferentiality between the subject of the verb and the topicalized constituent leads us to discuss another constraint imposed on Arabic structures.

Arabic allows the Q-phrase to move to the right position of the MI-topic, but not to its left. The grammaticality of such a condition can be exhibited in the following examples.

(27) a. $\frac{\text{zaydun}}{\text{Zayd}} \quad \frac{\text{kayfa}}{\text{how}} \quad \frac{\text{daraba}}{\text{hit}} \quad \frac{\emptyset\text{-Pro}}{\text{he}} \quad \frac{c_{\text{amran}}}{c_{\text{Amr}}} \quad ?$
 As for Zayd, how did he hit c_{Amr} ?

b. $\frac{\text{zaydun}}{\text{Zayd}} \quad \frac{\text{mata}}{\text{when}} \quad \frac{\text{daraba}}{\text{hit}} \quad \frac{\emptyset\text{-Pro}}{\text{he}} \quad \frac{c_{\text{amran}}}{c_{\text{Amr}}} \quad ?$
 As for Zayd, when did he hit c_{Amr} ?

Since (27a) and (27b) are grammatical, we can have a more adequate rule, as in (28).

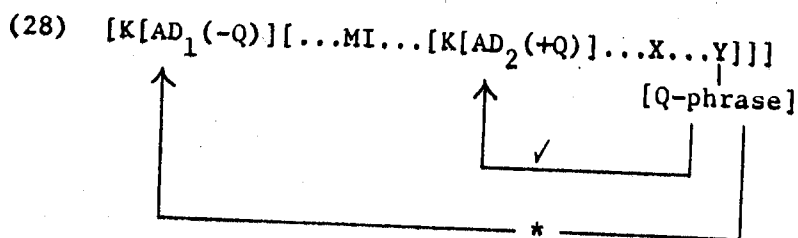

A transformational rule cannot move a Q-phrase to the domain of AD_1 , and it can move it to AD_2 only if X is V. This constraint will allow the structures of (27a,b) to have the following underlying structure (29).

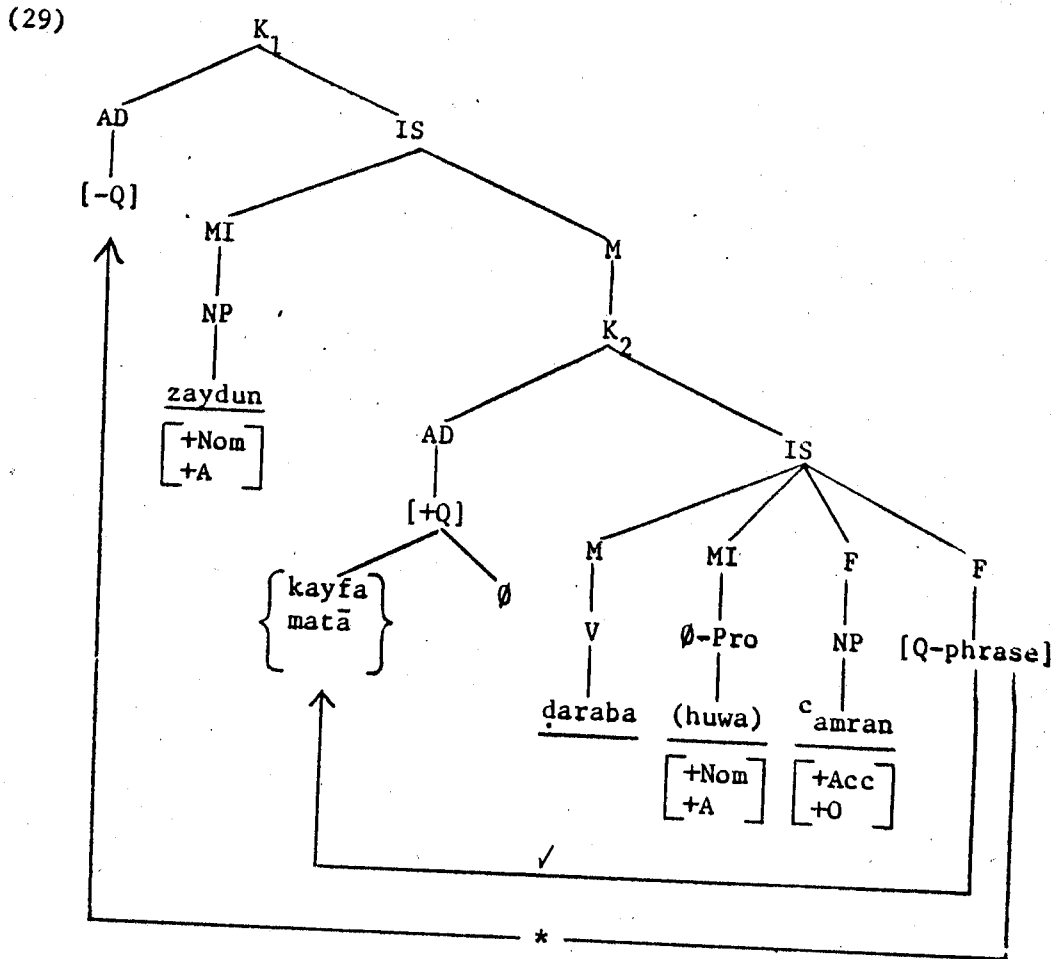

5. Conclusion

Any linguistic approach seeking a scientific investigation of empirical, exact, and objective analysis needs to be based on different varieties of linguistic data. In addition, it needs to be flexible in its theoretical principles in the sense of being able to benefit from the different linguistic data which belong to different languages.

In light of these facts, modern linguistic theory might benefit from the linguistic data presented in this study. At the same time, it would be useful in our contemporary Arabic language research to open our eyes to the tremendous

and advanced development in the technology of modern linguistics. In doing both tasks, we understand not only the linguistic system of the Arabic language adequately, but we can understand the mentality of the Arabs as well. Because my belief, like that of Hjelmslev (1961:127), is that "linguistic theory is led by an inner necessity to recognize not merely the linguistic system in its schema and its usage, in its totality and its individuality, but also man and human society behind language and all man's sphere of knowledge through language. At that point, linguistic theory has reached its prescribed goal: *humanitas et universitas.*"

Wa l-lāhu ?a^clam

BIBLIOGRAPHY

- Al-Jurjāni (d. 1078). Dalāʾil al-I^cjāz. Ed. Maktabatu l-qāhiraḥ, Egypt, 1961.
- _____. Al-jumal. Ed. Ḥaydar, A., Damascus, 1972.
- _____. Al-^cawāmil al-miʿah. Ed. in Istanbūl, 1924.
- Al-ʾistrābāʾi (d. 1289). Ṣarḥ al-Ṣāfiyah. Ed. Dār al-kutub al-^cilmiyyah. Beirut, 1975.
- _____. Ṣarḥ al-kāfiyah. Ed. Dār al-kutub al-^calmiyyah. Beirut, 1957.
- Anshen, F. and Schreiber, P. (1968). "A Focus Transformation of Modern Standard Arabic." Language 44.
- Aoun, Joseph (1979). "Ambiguity and Metric: The Symmetry Constraint." Alfikr Al-Arabi, Nos. 8 and 9.
- As-suyūṭi (d. 1518). Al-aṣbāḥ wa nnaḥāʾir. Ed. Maṭba^ct dāʾiratu l-ma^cārif al-uṯmaniyyah. Ḥaydar abād, 1940.
- _____. Al-muzhir fī ^culūm al-luḡah. Ed. Dār Iḥyāʾ al-kutub al-arabiyyah, Cairo, 1971.
- Al-tawḥīdi, Abū ḥayyān. Al-imtā^c wa l-muʿānasah. Eds. A. Amin and A. Az-zean, Egypt, 1960.
- Awwad, M. A. (1973). "Relativization and Related Matters in Classical Modern Standard and Palestinian Colloquial Arabic." Unpublished Ph.D. dissertation, Brown University, Providence, Rhode Island.
- Az-zajjāji (d. 944). Al-jumal. Ed. Ibn abi Ṣanab. Paris, 1957.

- Bakir, M. J. (1980). Aspects of Clause Structure in Arabic. Indiana University Linguistic Club, Indiana.
- Boas, Franz (1964). Introduction to the Handbook of American Indian Languages. Georgetown University Press, Washington, D. C.
- Brame, M. (1970). "Arabic Phonology: Implications for Phonological Theory and Historical Semitic." Unpublished Ph.D. dissertation, Massachusetts Institute of Technology, Cambridge, Massachusetts.
- Bresnan, Joan (1976). "On the Form and Functioning of Transformations." In Linguistic Inquiry 7 (1).
- Chafe, Wallace L. (1970). Meaning and the Structure of Language. University of Chicago Press.
- Chomsky, Noam (1970). Syntactic Structures. The Hague, Paris: Mouton.
- _____ (1965). Aspects of the Theory of Syntax. M.I.T. Press, Cambridge, Massachusetts.
- _____ (1970). "Remarks on Nominalization." In Readings in English Transformational Grammar. Eds. R. A. Jacobs and P. S. Rosenbaum. Georgetown University Press, Washington, D. C.
- _____ (1971). "Deep Structure, Surface Structure, and Semantic Interpretation." In Semantics: An Interdisciplinary Reader in Philosophy, Linguistics, and Psychology. Eds. Steinberg and Jakobovits.
- _____ (1975). Reflections on Language. Pantheon Books.
- _____ (1977). Essays on Form and Interpretation. North-Holland Publishing Company.

- _____ and Lasnik, Howard (1977). "Filters and Control." Linguistic Inquiry 8 (3).
- Chomsky, Noam (1977). "On Wh-Movement." In Wasow Culicover and Akmajian, ed., Formal Syntax. Academic Press.
- _____ (1980). "On Binding." Linguistic Inquiry 11 (1).
- _____ (1980). "On the Representation of Form and Function." Paper presented at conference at Royaumont.
- _____ (1981). Lectures on Government and Binding. Foris Publications.
- _____ (1981). "Lectures on Government and Binding." Class lectures, M.I.T. Fall 1981.
- Cook, Walter A. (1976). "Five Models of Case Grammar." Mimeograph. Georgetown University, Washington, D. C.
- _____ (1978). "Introduction to Transformational Grammar." Mimeograph. Georgetown University, Washington, D. C.
- _____ (1979). Case Grammar: Development of the Matrix Model (1970-1978). Georgetown University Press, Washington, D. C.
- _____ (1979). "Case Grammar and Generative Semantics." Georgetown University Press on Languages and Linguistics, Number 8. Georgetown University Press, Washington, D. C.
- _____ (1980). "Introduction to Generative Semantics." Mimeograph. Georgetown University, Washington, D. C.
- Dik, S. (1978). Functional Grammar. Ed. in North Holland, Amsterdam.

- Dinneen, Francis P. (1967). An Introduction to General Linguistics. Holt, Rinehart and Winston, Inc.
- Emonds, Joseph E. (1976). A Transformational Approach to English Syntax: Root, Structure-Preserving, and Local Transformations. Academic Press.
- Fehri, Fassi Abdelkader (1981). "Complementation et Anaphore en Arabe Moderne: Une Approche Lexicale Fonctionnelle." These de Doctorat d'Etat. Universite de Paris III.
- Fillmore, Charles J. (1968). "The Case for Case." In Universals in Linguistic Theory. Edited by Emmon Bach and Robert T. Harms. Holt, Rinehart and Winston, Inc.
- _____ (1977). "The Case for Case Reopened." In Syntax and Semantics, Vol. 8: Grammatical Relations. Edited by Peter Cole and Jerrold M. Sadok. Academic Press.
- Gruber, Jeffrey S. (1965). "Studies in Lexical Relations." Unpublished Ph.D. dissertation, M.I.T.
- Hale, Kenneth (1981). "Introduction to Linguistics 1: Syntax." Class lectures. M.I.T. Fall 1981.
- Halle, Morris (1981). "General Linguistics." Class lectures. M.I.T. Fall 1981.
- Hjelmslev, Louis (1961). Prolegomena to a Theory of Language. Translated by Francis J. Whitfield. Madison, Wisconsin.
- Ibn ya^Cī^Y (d. 1250). Ṣarḥ al-mufaṣṣal. Ed. Alam al-kutub, Beirut, 1970.
- Ibn Hiṣām (d. 1368). Muḡnī al-labīb. Eds. Al-mubāarak and M. S. Hamadallah. Dār al-fikr, Damascus, 1969.

- Ibn jinni (d. 1002). Al-xaṣāʾiṣ. Ed. An-najjār M. A. Dār al-hudā, Beirut, 1952..
- IPA (1975). The Principles of the International Phonetic Association. University College, London.
- Jackendoff, Ray (1972). Semantic Interpretation in Generative Grammar. M.I.T. Press.
- _____ (1976). "Toward an Explanatory Semantic Representation." Linguistic Inquiry 7 (1).
- Katz, J. J. and Fodor, J. A. (1963). "The Structure of a Semantic Theory." Language 39.
- Katz, J. J. and Postal, P. M. (1964). An Integrated Theory and Linguistic Descriptions. M.I.T. Press.
- Killean, C. (1966). "The Deep Structure of the Noun Phrase in Modern Written Arabic." Unpublished Ph.D. dissertation, University of Michigan, Ann Arbor, Michigan.
- Lakoff, George (1970). Irregularity in Syntax. Rinehart and Winston, Inc., New York.
- Lakoff, George, and Peters, Stanley (1969). "Phrase Conjunction and Symmetric Predicates." In Modern Studies in English. Eds. David Reibel and Sanford Schane. Prentice-Hall, New Jersey.
- Lewkowicz, N. (1967). "A Transformational Approach to the Syntax of Arabic Particles." Unpublished Ph.D. dissertation, University of Michigan, Ann Arbor, Michigan.
- Sībawahi (d. 793). Al-kitāb. Ed. Dār al-qalam, Egypt, 1966, and būlāq, 1898.

Snow, J. (1965). "A Grammar of Modern Written Arabic Clauses." Unpublished Ph.D. dissertation, University of Michigan, Ann Arbor, Michigan.

Soames, Scott and Perlmutter, David M. (1979). Syntactic Argumentation and the Structure of English. University of California Press.

BIOGRAPHICAL NOTE

The author was born on January 11, 1952, in Homs, Syria. He received his A.B. in Arabic Literature in 1974 from Damascus University. He received his diploma in graduate literature studies in 1976 from Damascus University.

In 1977, he was granted a full scholarship to study the English language and henceforth linguistics. He finished his English proficiency in 1978 from the American Language Institute at Georgetown University. He earned his M.S. in Linguistics from Georgetown University in 1980.

In 1980, he was granted a full scholarship to attend the Fifth International Linguistic Institute held in Damascus, Syria. In 1981-1982, he was accepted as a visiting scholar at the Massachusetts Institute of Technology for advanced research in TGG. In 1982, he was granted a full scholarship to attend the Seventh International Linguistic Institute held in Rabat, Morocco.

He completed the requirements for a Ph.D. in Linguistics at Georgetown University in May 1983. He will be teaching and doing research in Linguistics in the Department of Arabic and English at Damascus University. His publications include:

- 1983 "Toward a Modern Linguistic Model of Arabic: The Semantic Theory in Traditional Arabic Thought," Al-Mawqif Al-Adabi. Issued by the Union of Arab Writers in Damascus, Syria. (In Arabic) (Forthcoming)
- 1983 "The Crisis of Linguistics and Linguists in the Arab World," Al-Ma^crifa, No. 251. Issued by the Ministry of Culture and National Guidance in Damascus, Syria. (In Arabic)
- 1983 "On the Biological Basis of Language Capacities," by Noam Chomsky. Translated and explained by Mazen Al-Waer. In Some Linguistic and Discourse Issues. Ed. A. Fasi Fehri, Rabat, Morocco. (In Arabic)
- 1983 "The Semantic and Syntactic Frame Structure of the Verb 'SEE' in Arabic and English: A Case Grammar Approach," Al-Lisān Al-^cArabi, No. 21. Issued by the Bureau of Coordination of Arabization in Rabat, Morocco. (In English)
- 1983 "The Semantic and Syntactic Frame Structure of the Transitive and Intransitive Verb Category in Arabic and English: Generative Semantic Approach," Al-Lisān Al-^cArabi, No. 20. Issued by the Bureau of Coordination of Arabization in Rabat, Morocco. (In English)
- 1982 "The Syntactic and Semantic Aspects of Transformational Generative Grammar," Al-Lisāniyyāt, No. 6. Issued by the Linguistics Institute of Algiers, Algiers. (In Arabic)

- 1982 "On Some Controversial Issues of Transformational Generative Grammar: A Dialogue with Noam Chomsky," Al-Lisāniyyāt, No. 6. Linguistics Institute of Algeria, Algiers. (In Arabic and English)
- 1982 "The Arabic Phonetics," Al-Ma^Crifa, No. 240. Issued by the Ministry of Culture and National Guidance in Damascus, Syria. (In Arabic)
- 1981 "The Poetic, Linguistic and Philosophical Dimensions of Risālat Al-Ghufrān," At-turāth Al-^CArabi, No. 4. Issued by the Union of Arab Writers, in Damascus, Syria. (In Arabic)
- 1981 "Some Linguistic Researches by Al-Jāhi^X and Their Place in Modern Linguistics," Al-Ma^Crifa, No. 234. Issued by the Ministry of Culture and National Guidance in Damascus, Syria. (In Arabic)
- 1980 "Linguistics from Structuralism to Transformationalism," Al-Ma^Crifa, Nos. 220-21. Issued by the Ministry of Culture and National Guidance in Damascus, Syria. (In Arabic)
- 1980 "Biological Linguistics," Al-Ma^Crifa, Nos. 222-23. Issued by the Ministry of Culture and National Guidance in Damascus, Syria. (In Arabic)
- 1980 "Back Again to Biological Linguistics: A Survey of the American Experience," Al-Ma^Crifa, Nos. 225-26. Issued by the Ministry of Culture and National Guidance in Damascus, Syria. (In Arabic)
- 1979 "On the Fifth International Congress of Applied Linguistics: A Dialogue with the French Linguist André Martinet," Al-Ma^Crifa, No. 203. Issued by the Ministry of Culture and National Guidance in Damascus, Syria. (In Arabic)

- 1978 "Linguistics as a Scientific Study of Languages," Al-Ma^crifa, No. 195. Issued by the Ministry of Culture and National Guidance in Damascus, Syria. (In Arabic)
- 1978 "Why Linguistics?" Al-Ma^crifa, No. 199. Issued by the Ministry of Culture and National Guidance in Damascus, Syria. (In Arabic)